

PRODUCT MANUAL

EIGHT-CHANNEL PIEZOELECTRIC
SENSOR CONNECTOR

PZ-8



PRODUCT MANUAL

EIGHT-CHANNEL PIEZOELECTRIC SENSOR CONNECTOR

PZ-8

INTRODUCTION

DISCLAIMER	III
PRIVACY	III
ALERTS	III
ABBREVIATIONS	III

PRODUCT DESCRIPTION

APPLICATIONS	1
MULTI-CHANNEL PIEZOELECTRIC SENSOR SYSTEM	1
OPERATION	1
SENSOR CONNECTORS	1
PIEZOELECTRIC SENSORS	1
DIMENSIONS	2
CABLE LENGTHS	2

INSTALLATION

INSTALLATION OVERVIEW	3
INSTALLATION SPECIFICATIONS	4
CONNECTOR POCKET	5
INSTALLATION OPTIONS	6
LEGACY EIGHT-CHANNEL PIEZOELECTRIC SENSOR CONNECTOR PZ-8 INSTALLATION	6

PRODUCT MANUAL

EIGHT-CHANNEL PIEZOELECTRIC SENSOR CONNECTOR

PZ-8

MAINTENANCE

CLEANING & DRIFT	7
REGULAR CLEANING	7
DRIFT	7
TESTING & CALIBRATION	7
SENSOR TESTING	7
WARRANTY	8
RJG, INC. STANDARD ONE-YEAR WARRANTY	8
PRODUCT DISCLAIMER	8

TROUBLESHOOTING

COMMON ERRORS	9
SLOW SENSOR DRIFT READING	10
FAST SENSOR DRIFT/INVALID READING	11
SENSOR DOES NOT COMMUNICATE WITH EDART	12
CUSTOMER SUPPORT	13

RELATED PRODUCTS

COMPATIBLE PRODUCTS	15
MULTI-CHANNEL PIEZOELECTRIC SENSOR CONNECTOR CABLE C-PZ/1645	15
EIGHT-CHANNEL PIEZOELECTRIC SENSOR CONNECTOR TO ADAPTER CABLE C-PZ/LX8F-S	15
LYNX EIGHT-CHANNEL PIEZOELECTRIC SENSOR ADAPTER WITH MOLD ID PZ/LX8F-S-ID	15
SIMILAR PRODUCTS	16
FOUR-CHANNEL PIEZOELECTRIC SENSOR CONNECTOR PZ-4	16
LYNX™ FOUR-CHANNEL PIEZOELECTRIC SENSOR ADAPTER PZ/LX4F-S-ID16	
FOUR-CHANNEL PIEZOELECTRIC SENSOR CONNECTOR TO ADAPTER CABLE C-PZ/LX4F-S	16

INTRODUCTION

Read, understand, and comply with all following instructions. This guide must be kept available for reference at all times.

DISCLAIMER



Inasmuch as RJG, Inc. has no control over the use to which others may put this material, it does not guarantee that the same results as those described herein will be obtained. Nor does RJG, Inc. guarantee the effectiveness or safety of any possible or suggested design for articles of manufacture as illustrated herein by any photographs, technical drawings, and the like. Each user of the material or design or both should make his own tests to determine the suitability of the material or any material for the design as well as the suitability of the material, process, and/or design for his own particular use. Statements concerning possible or suggested uses of the material or designs described herein are not to be construed as constituting a license under any RJG, Inc. patent covering such use or as recommendations for use of such material or designs in the infringement of any patent.

PRIVACY

Designed and developed by RJG, Inc. Manual design, format and structure copyright 2023 RJG, Inc. content documentation copyright 2023 RJG, Inc. All rights reserved. Material contained herein may not be copied by hand, mechanical, or electronic means, either whole or in part, without the express written consent of RJG, Inc. Permission will normally be granted for use in conjunction with inter-company use not in conflict with RJG's best interests.

ALERTS

The following three alert types are used as needed to further clarify or highlight information presented in the manual:

-  **DEFINITION** *A definition or clarification of a term or terms used in the text.*
-  **NOTES** *A note provides additional information about a discussion topic.*
-  **CAUTION** *A caution is used to make the operator aware of conditions that can cause damage to equipment and/or injury to personnel.*

ABBREVIATIONS

DIA	diameter
MIN	minimum
MAX	maximum
R.	radius

PRODUCT DESCRIPTION

The eight-channel piezoelectric connector with mold ID PZ-8 interfaces up to eight piezoelectric sensors with the RJG, Inc. eight-channel piezoelectric sensor adapter PZ/LX8F-S-ID and the eDART® or CoPilot® systems.

APPLICATIONS

MULTI-CHANNEL PIEZOELECTRIC SENSOR SYSTEM

The Lynx™ multi-channel piezoelectric systems provide quick, convenient connection between multiple sensors in a mold to a single sensor adapter outside of the mold and the eDART or CoPilot system, saving real estate on the mold and minimizing cabling.

OPERATION

SENSOR CONNECTORS

The PZ-8 contains the necessary hardware to connect piezoelectric sensors and cables inside the mold to the piezoelectric sensor adapter and cable outside of the mold. The connector is a self-identifying device, enabling automatic recognition of the sensors and connector when connected to the eDART or CoPilot System. The connector can withstand temperatures up to 392 °F (200 °C) MAX, with a Mold ID functionality MAX of 257 °F (125 °C).



PIEZOELECTRIC SENSORS

Piezoelectric sensors use quartz crystals to measure the deformation, or change in resistance, of the force over the sensor. The measurement is carried through the sensor cable to a sensor connector mounted on the outside of the mold.

The sensor connector is connected to a sensor adapter, which is then connected to the RJG, Inc. eDART or CoPilot system. The eDART and CoPilot system records and displays the sensor's measurement for operator aid in process monitoring and control.

DIMENSIONS

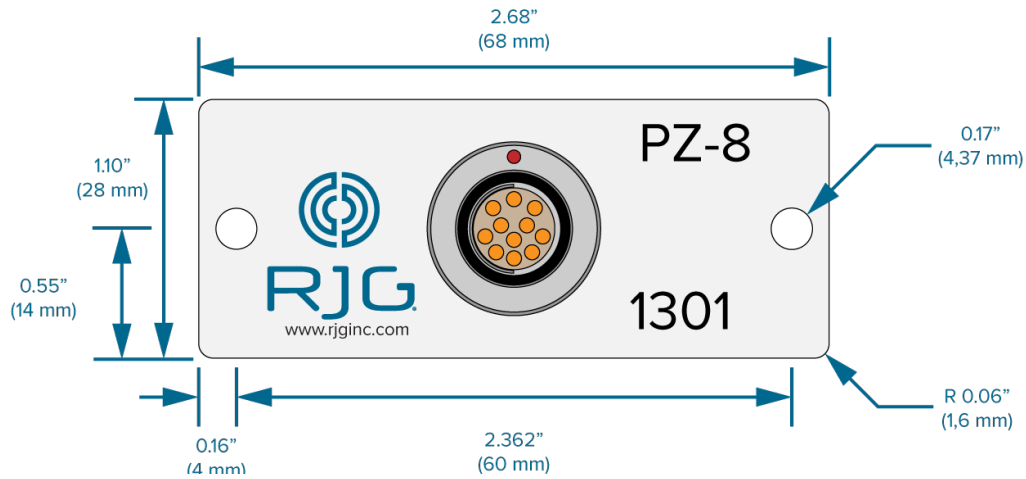

CABLE LENGTHS

Lengths must be longer than needed to facilitate safe installation and removal of connector from tool to prevent tension on

the lead wire; generally, 2–3" (50–75 mm) of slack is sufficient. Use good sense to determine the appropriate cable length required for each application.



Sensor-to-Connector Cable C/PZ-1645 Length



Connector-to-Adapter Cable C-PZ/LX8F-S Length

CABLE LENGTH

PART NO.

7.9"	0.2 m	C-PZ/1645-0.2
15.7"	0.4 m	C-PZ/1645-0.4
23.6"	0.6 m	C-PZ/1645-0.6
31.5"	0.8 m	C-PZ/1645-0.8
47.2"	1.2 m	C-PZ/1645-1.2
63.0"	1.6 m	C-PZ/1645-1.6
78.7"	2.0 m	C-PZ/1645-2.0

CABLE LENGTH

PART NO.

19.7"	0.5 m	C-PZ/LX8F-S-.5M
39.4"	1.0 m	C-PZ/LX8F-S-1M
78.7"	2.0 m	C-PZ/LX8F-S-2M

INSTALLATION

INSTALLATION OVERVIEW

A pocket is machined into the clamp and cover plates in conjunction with sensor pockets and cable channels for the sensor connector (refer to Piezoelectric Sensor Manuals for sensor and cable installation). The connector is installed in the pocket where the sensor cables, C-PZ/1645,

are able to connect to the back of the connector plate. A separate cable, C-PZ/LX8F-S, is installed on the connector outside of the mold, and joins the connector to the sensor adapter PZ/LX8F-S-ID, which is attached to the eDART or CoPilot system.

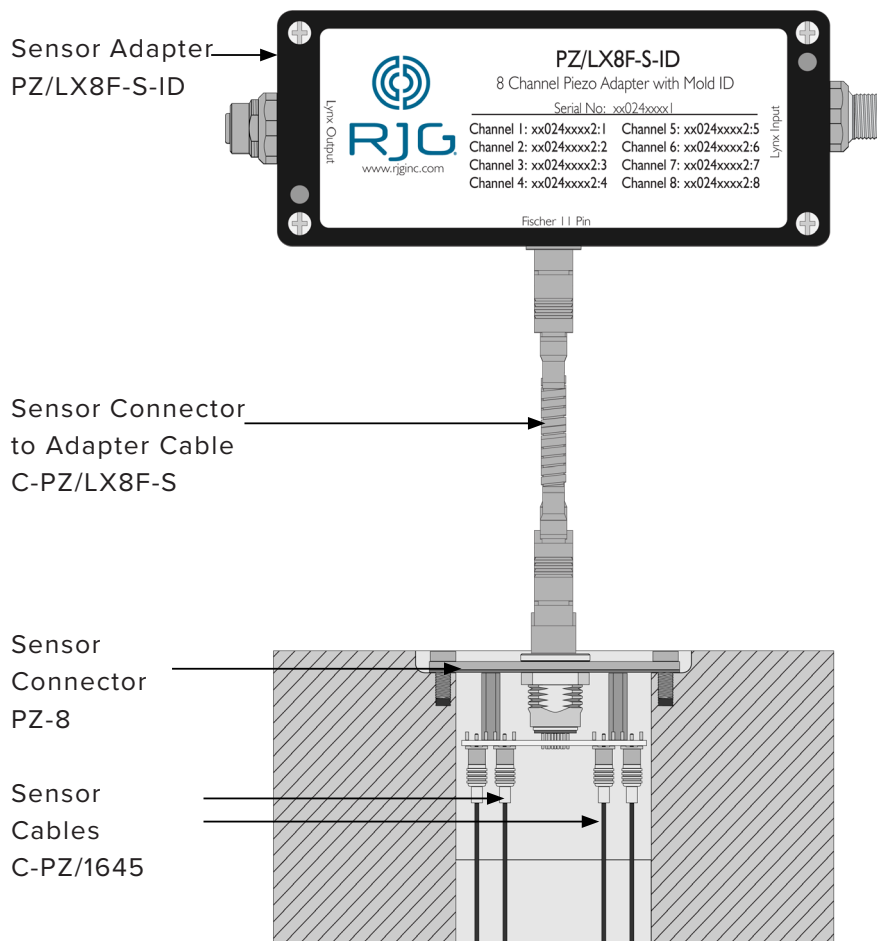
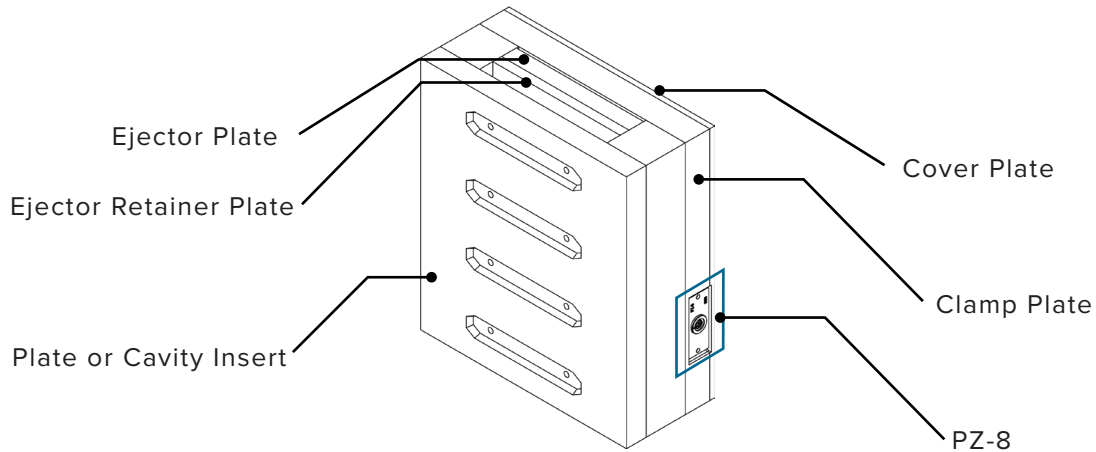

INSTALLATION SPECIFICATIONS

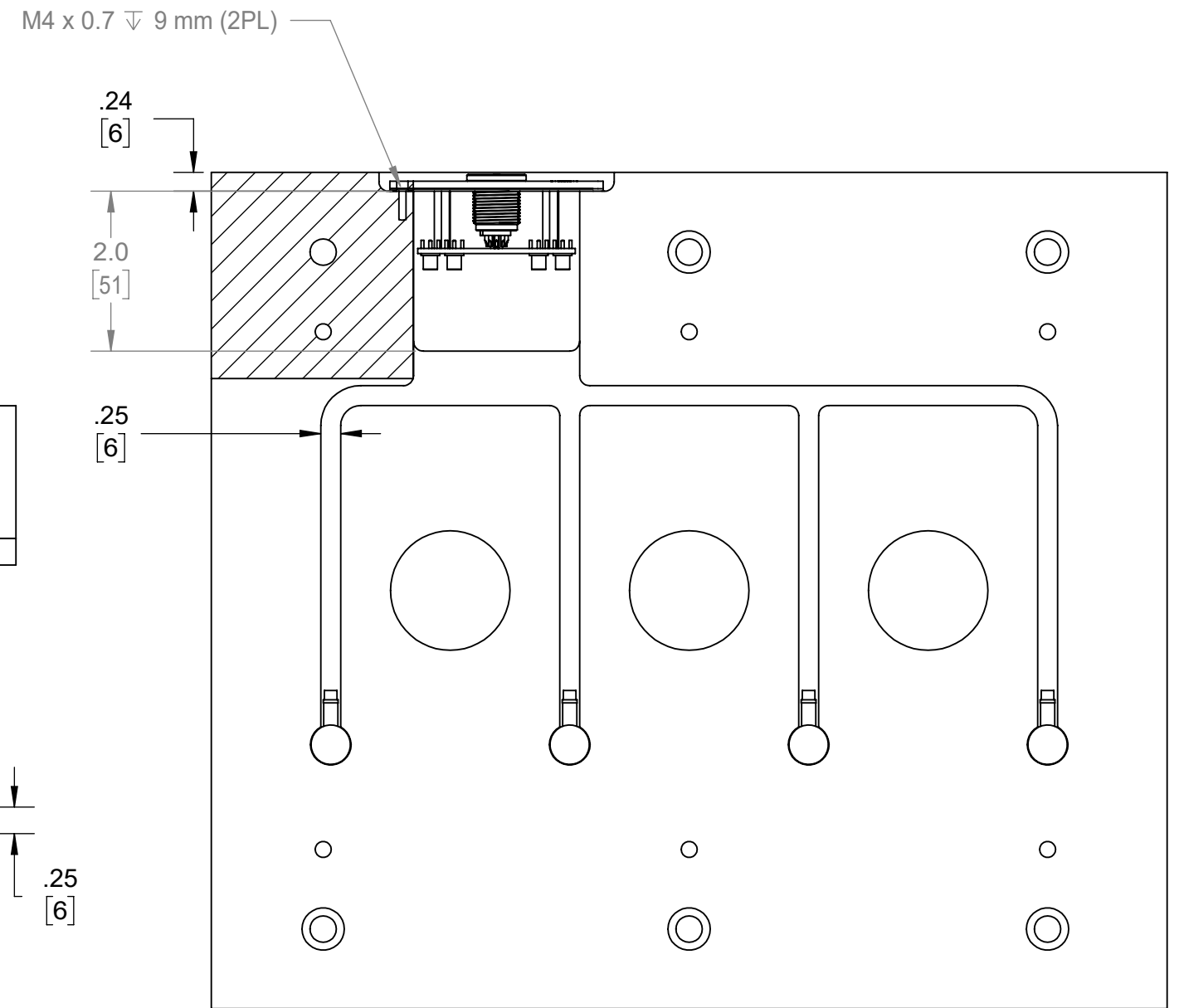
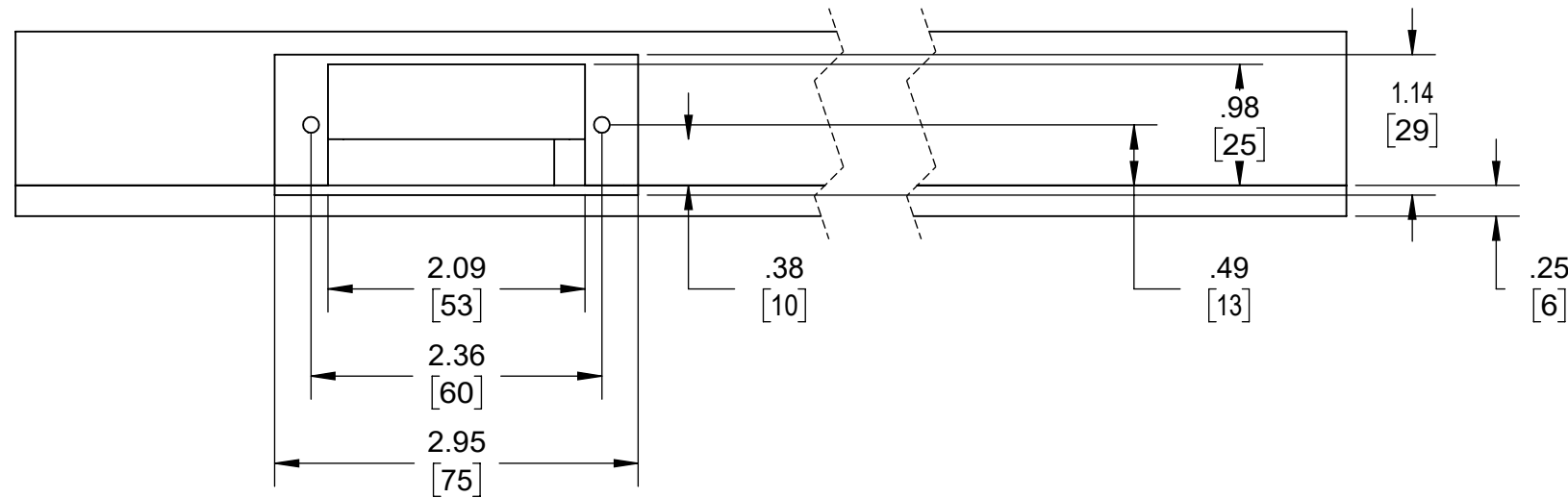
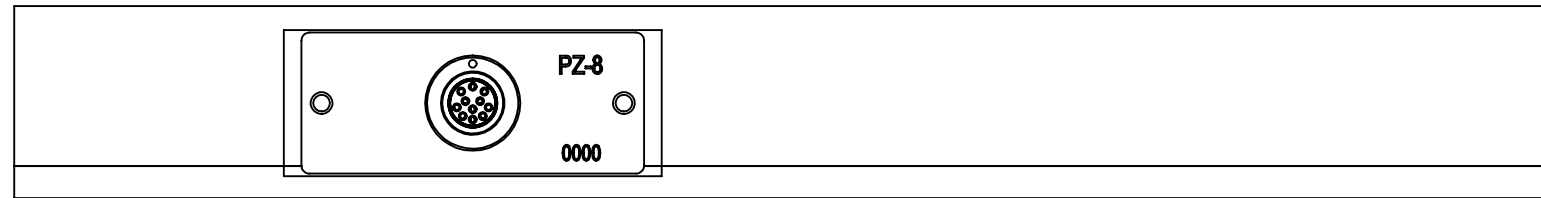
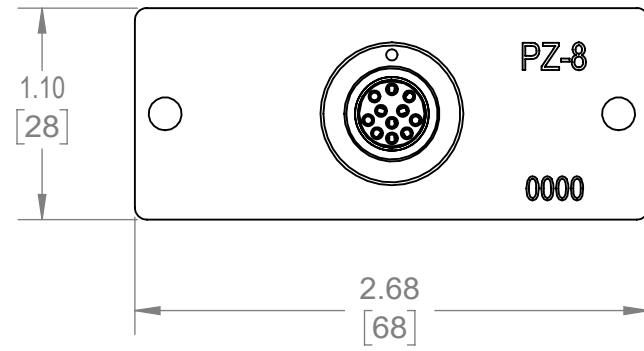

INSTALLATION SPECIFICATIONS (continued)

CONNECTOR POCKET

Machine a pocket for the connector into the clamp and cover plates. The PZ-8 plate requires a pocket of 2.95" (75 mm) wide by 1.14" (29 mm) deep for the outer connection side—optionally, it may be recessed into the clamp and cover plate 0.24" (6 mm) [1–3 at right]).

The PZ-8 plate requires a pocket of 2.0" (51 mm) MIN high by 2.09" (53 mm) wide by 1.02" (26 mm) deep for the inner, sensor-connections side (4–6 at right) in the clamp plate.

In addition, the remaining cable channel below the specified inner connection pocket must be 0.38" (9,53 mm) wide by 0.25" (6,35 mm) MIN deep per cable to the sensor head (7–8 at right).

Dill and tap 2.36" (60 mm) on center in the connector pocket for the included M4 socket head cap screws 0.35" (9 mm [9–10 at right]) deep.

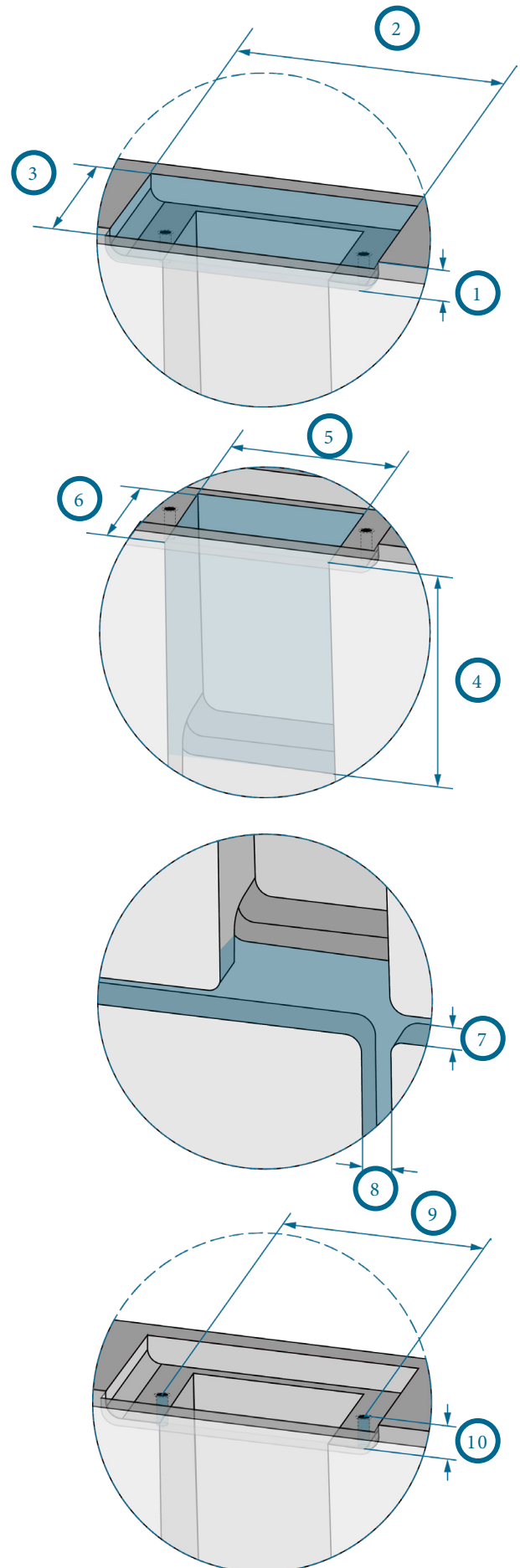

1	0.24" (6 mm)
2	2.95" (75 mm)
3	1.14" (28,96 mm) MIN
4	2.0" (51 mm)
5	2.09" (53 mm)
6	0.98" (25 mm)
7	0.38" (9,53 mm)
8	0.25" (6,35 mm) MIN per cable
9	2.36" (60 mm)
10	0.35" (9 mm)

INSTALLATION OPTIONS

LEGACY EIGHT-CHANNEL PIEZOELECTRIC SENSOR CONNECTOR PZ-8 INSTALLATION

The legacy eight-channel piezoelectric sensor connector PZ-8, version one, requires a different pocket dimension than the previously-described PZ-8, version two. If needed, a spacer is available for the legacy installation—contact RJG, Inc. Customer Support for more details.

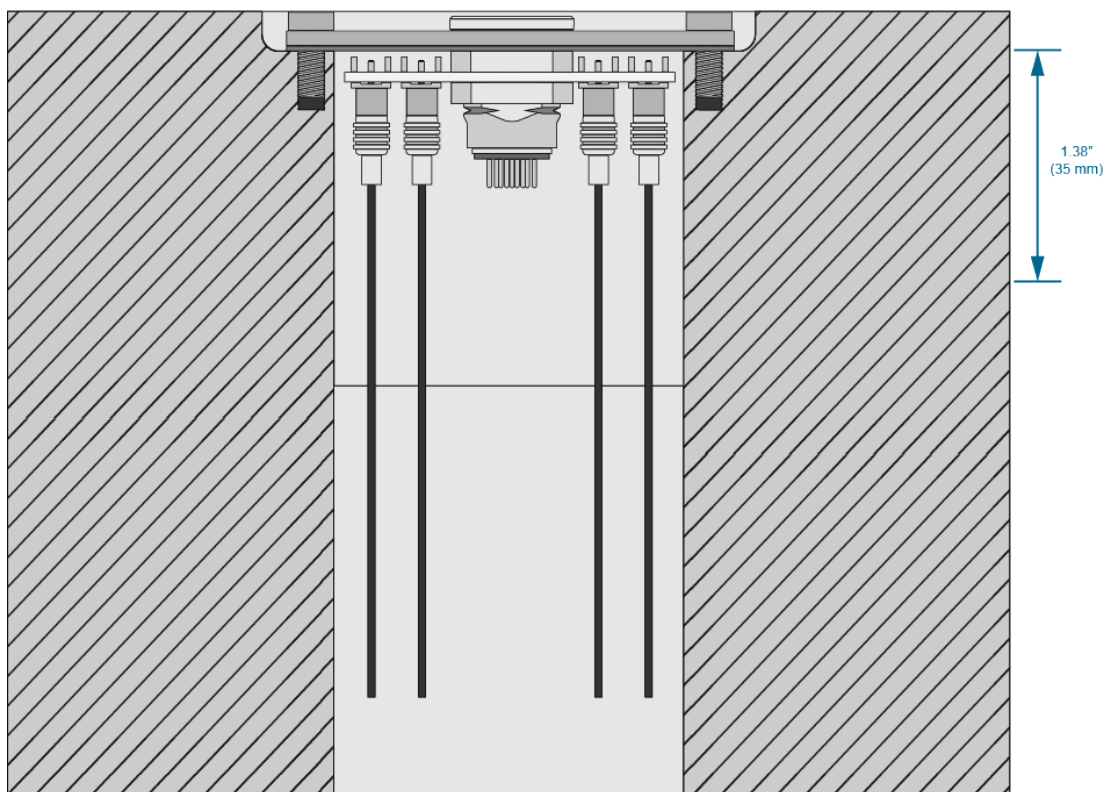

CLEANING & DRIFT

REGULAR CLEANING

Pull sensors from the mold and clean out the pockets and channels when a mold is pulled for preventative maintenance. Sensors, connectors, and cables must be installed in areas free from oil, dirt, grime, and grease.

RJG, Inc. recommends the following cleaners:

- MicroCare MCC-CCC Contact Cleaner C
- MicroCare MCC-SPR SuprClean™
- Miller-Stephenson MS-730L Contact Re-Nu®

DRIFT

Piezoelectric sensors can drift negative (-) or positive (+). The acceptable drift specification for RJG piezoelectric sensors is 20 pC/minute. The easiest place to monitor this is the eDART “Sensor Locations” screen. Drift of ± 20 pC in sixty seconds indicates abnormal drift. The cause of “Drift” is dirty/contaminated connections. This could be any of the connections from the sensor to the eDART.

Properly clean all connection points with an electronics grade contact cleaner. Allow the sensors and cables to air-dry before reconnecting them. Do not blow them out with a “shop” air line as this air usually contains oil and other contaminants.

If drift continues, clean the sensors out again with electronics grade cleaner then bake them in an oven to remove the contaminants (same method used at RJG). It is recommended to bake the sensors/cables at 212 °F (100 °C) for sixty minute bake the plate/adaptor at 140 °F (60 °C).

If continuing to experience drift after this, please contact RJG Sales for pricing and lead time on replacement items.

TESTING & CALIBRATION

The Eight-Channel Piezoelectric Sensor Connector PZ-8 features high resolution and low drift ratings and requires no calibration. Follow all instructions and recommendations for individual sensor testing and calibration for optimal operation.

SENSOR TESTING

1. Sensor PreCheck

The Sensor PreCheck provides diagnostics on typical sensor problems such as sensor drift, preload, and zero shift, and can also detect sensor installation errors caused by improper pocket dimensions, damaged wires, and damaged sensor heads. A test report with sensor configuration can be emailed or printed from the device. This device allows testing of up to thirty-two sensors at one time and can verify that a force was applied to the sensor.

2. eDART Software—Raw Data Viewer

The eDART Raw Data Viewer displays the status of the sensor, either Valid, No Reply, Stale, or Invalid.

- A Valid sensor has raw counts that change when force is applied to the sensor; this indicates a properly working sensor.
- A No Reply sensor is not communicating with the eDART; the sensor may be unplugged.
- A Stale sensor indicates a sensor that is unused.
- An Invalid sensor will indicate a Failure of either Over-range (Ovrng) or Under-range (Undrng). The Ovrng indicates the sensor’s calibration has changed too far in a positive direction, outside of the upper specification. The Undrng indicates that the sensor’s calibration has changed too far in a negative direction, and the sensor may report a number below zero when load is applied.

WARRANTY

RJG, INC. STANDARD ONE-YEAR WARRANTY

RJG, Inc. is confident in the quality and robustness of the PZ-8, and so are offering a one-year warranty. RJG's multi-channel piezoelectric sensor connectors are guaranteed against defects in material and workmanship for one year from the original date of purchase. The warranty is void if it is determined that the product was subjected to abuse or neglect beyond the normal wear and tear of field use, or in the event the product has been opened by the customer.

PRODUCT DISCLAIMER

RJG, Inc. is not responsible for the improper installation of this equipment, or any other equipment RJG manufactures.

Proper RJG equipment installation does not interfere with original equipment safety features of the machine. Safety mechanisms on all machines should never be removed.

TROUBLESHOOTING

COMMON ERRORS

1. Slow sensor drift reading.

A sensor reading that slowly rises or falls (positive or negative) from the set zero value.

2. Fast sensor drift/invalid reading.

A sensor reading that quickly or rises or falls (positive or negative) from the set zero value, possibly so much that the reading becomes invalid.

3. No sensor to eDART/CoPilot system communication.

The sensor reading cannot be obtained by the eDART or CoPilot system.

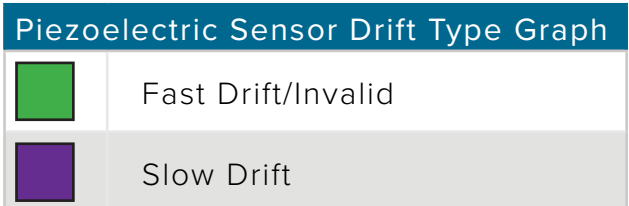
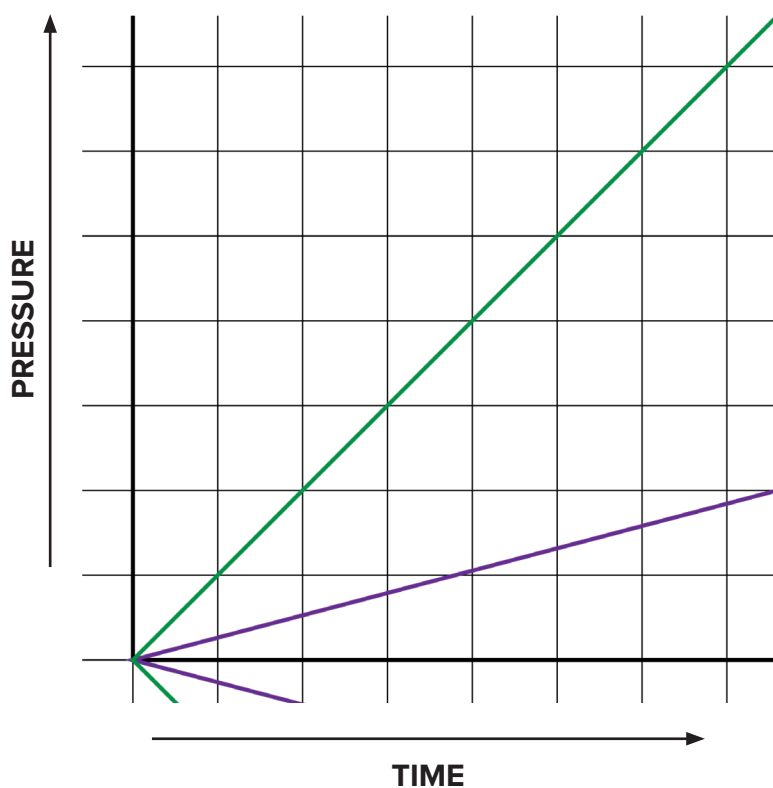

COMMON ERRORS *(continued)*

SLOW SENSOR DRIFT READING

If the sensor reading will not remain steady and drifts positive or negative, the sensor, cables, or adapter connectors may be contaminated. To identify the connector(s) with contamination, perform the following:

1. Disconnect the C-PZ/LX8F-S cable from the PZ/LX8F-S-ID and clean end and connector; if the reading continues to drift, continue to next step.
2. Disconnect the C-PZ/LX8F-S cable from the PZ-8 and clean end and connector; if the reading continues to drift, continue to next step.
3. Disconnect the C-PZ/1645 from the PZ-8 and clean ends; if the reading continues to drift, continue to next step.
4. Disconnect sensor from C-PZ/1645 cable and clean ends.

If the sensor reading continues to drift after the above troubleshooting steps are completed, either the sensor, cables, connector, or adapter must be replaced; contact RJG Customer Support.

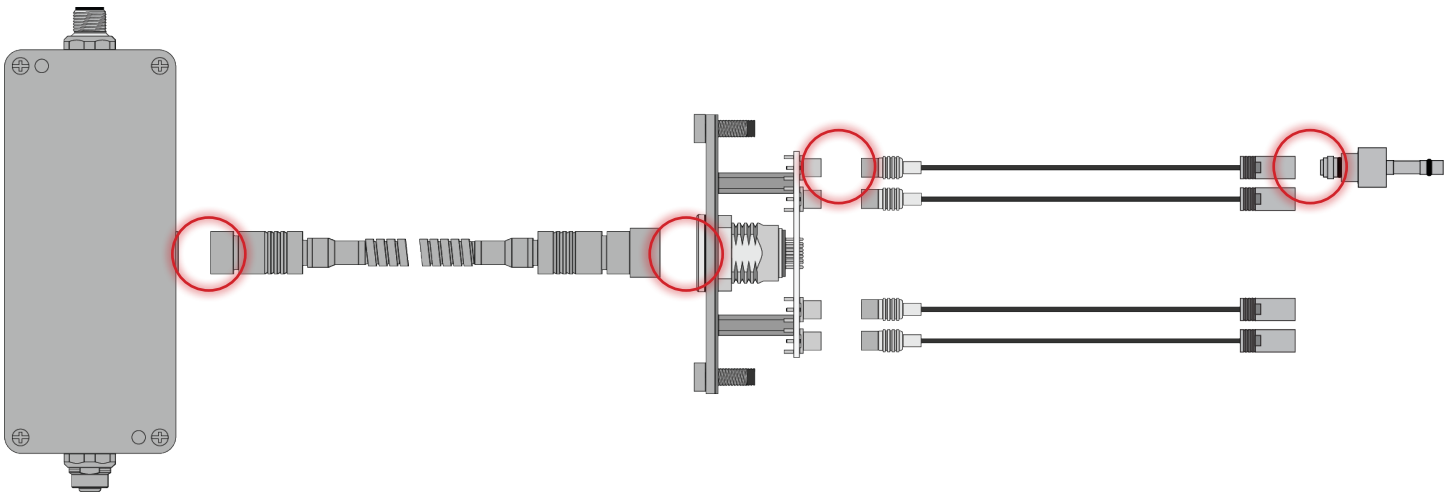

COMMON ERRORS *(continued)*

FAST SENSOR DRIFT/INVALID READING

If the sensor reading drifts quickly and becomes invalid, the sensor, cables, or adapter connectors may be heavily contaminated, or the adapter may have failed. To identify the connector(s) with contamination, perform the following:

1. Disconnect the C-PZ/LX8F-S cable from the PZ/LX8F-S-ID and clean end and connector; if the reading continues to drift, continue to next step.
2. Disconnect the C-PZ/LX8F-S cable from the PZ-8 and clean end and connector; if the reading continues to drift, continue to next step.
3. Disconnect the C-PZ/1645 from the PZ-8 and clean ends; if the reading continues to drift, continue to next step.
4. Disconnect sensor from C-PZ/1645 cable and clean ends; if reading continues to drift, continue to next step.

If the sensor reading continues to drift or remains invalid after the above troubleshooting steps are completed the adapter must be replaced; contact RJG Customer Support.

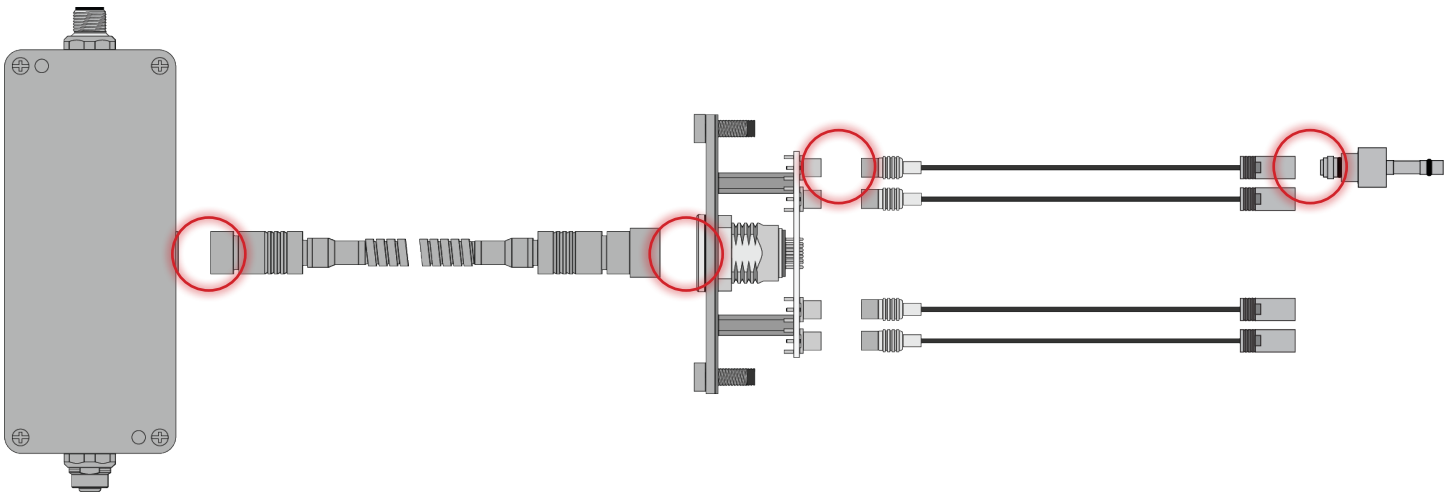

COMMON ERRORS *(continued)*

SENSOR DOES NOT COMMUNICATE WITH EDART

If the eDART is unable to establish communication with the sensor, the cables or adapter may have failed. To identify the failed component, perform the following;

1. Replace the CE-LX5 Lynx cable with working cable; test the sensor operation.
2. Replace the C-PZ/LX8F-S sensor adapter cable with working cable; test sensor operation. If communication remains non-existent, continue to next step.
3. Replace the C-PZ/1645 sensor cable with working cable; test sensor operation.

If the eDART or CoPilot System cannot establish communication after these steps, the connector has failed and must be replaced; contact RJG Customer Support.

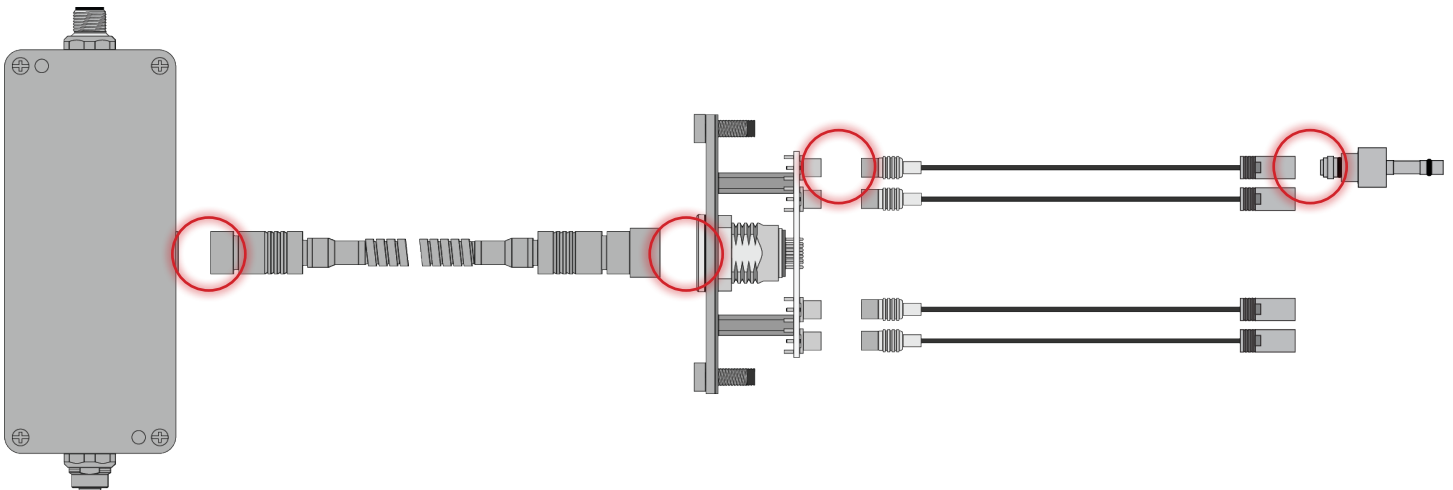

CUSTOMER SUPPORT

Contact RJG's Customer Support team by phone or email.

RJG, Inc. Customer Support

P: 800.472.0566 (Toll Free)

P: +1.231.933.8170

email: CustomerSupportGroup@rjginc.com

www.rjginc.com/support

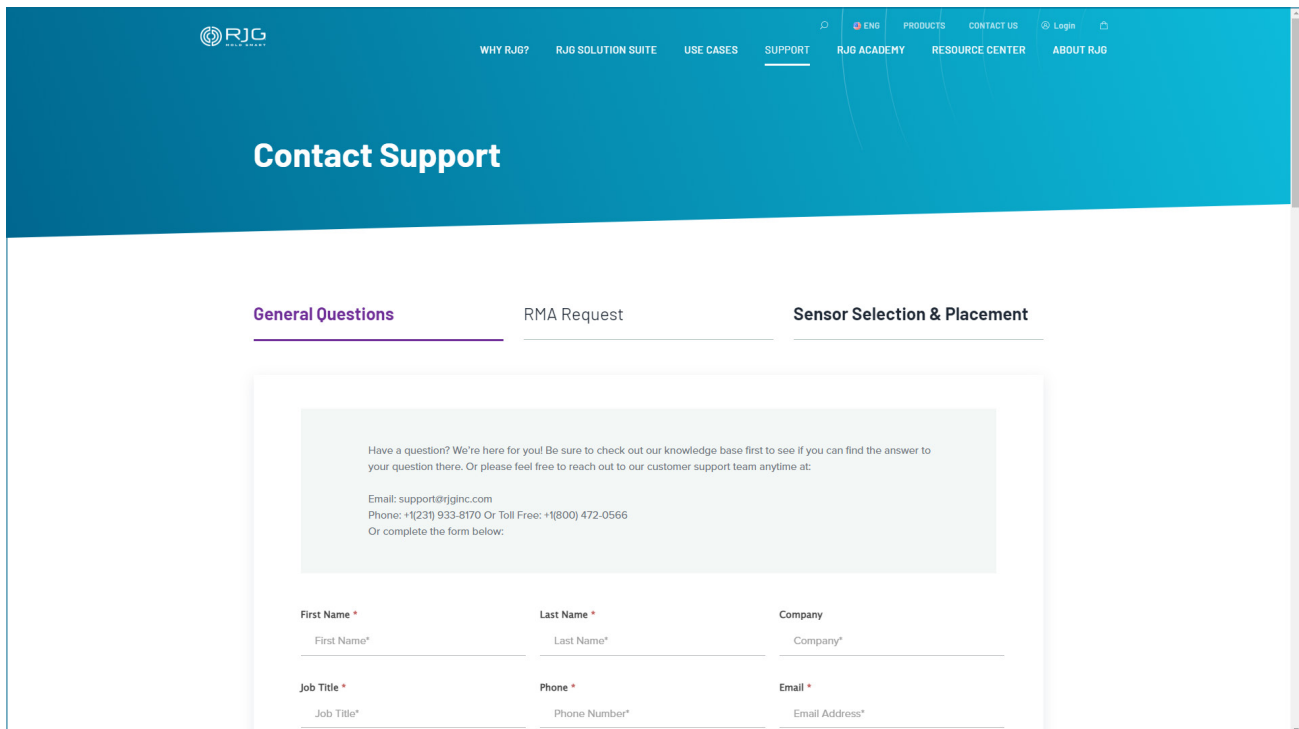

The screenshot shows the 'Contact Support' page on the RJG website. The page has a blue header with the RJG logo and navigation links: WHY RJG?, RJG SOLUTION SUITE, USE CASES, SUPPORT (highlighted), RJG ACADEMY, RESOURCE CENTER, and ABOUT RJG. There are also links for ENG, PRODUCTS, CONTACT US, and Login. Below the header, the 'Contact Support' title is displayed. Three tabs are visible: 'General Questions' (selected), 'RMA Request', and 'Sensor Selection & Placement'. The 'General Questions' tab contains a text box with the following text: 'Have a question? We're here for you! Be sure to check out our knowledge base first to see if you can find the answer to your question there. Or please feel free to reach out to our customer support team anytime at: Email: support@rjginc.com Phone: +1(231) 933-8170 Or Toll Free: +1(800) 472-0566 Or complete the form below:'. Below this text is a form with six input fields: 'First Name *', 'Last Name *', 'Company', 'Job Title *', 'Phone *', and 'Email *'. Each field has a corresponding label and a placeholder text.

RELATED PRODUCTS

The PZ-8 is compatible with other RJG, Inc. products for use with the eDART or CoPilot process control and monitoring system.

COMPATIBLE PRODUCTS

MULTI-CHANNEL PIEZOELECTRIC SENSOR CONNECTOR CABLE C-PZ/1645

The C-PZ/1645 piezoelectric sensor cable (1 at right) is designed for use with the RJG, Inc. four and eight-channel piezoelectric sensor connectors PZ-4 and PZ-8 with mold ID. Up to eight C-PZ/1645 cables can be used to interface sensors to the PZ-8.



EIGHT-CHANNEL PIEZOELECTRIC SENSOR CONNECTOR TO ADAPTER CABLE C-PZ/LX8F-S

The C-PZ/LX8F-S eight-channel piezoelectric sensor connector-to-adapter cable (2 at right) is designed for use with the RJG, Inc. eight-channel piezoelectric adapter with mold ID PZ-LX8F-S-ID. One C-PZ/LX8F-S is required to interface the PZ-8 with the PZ/LX4F-S-ID and the eDART or CoPilot system.



LYNX EIGHT-CHANNEL PIEZOELECTRIC SENSOR ADAPTER WITH MOLD ID PZ/LX8F-S-ID

The Lynx eight-channel piezoelectric sensor adapter with mold ID PZ/LX8F-S-ID (3 at right) provides a quick, convenient connection between the RJG, Inc. eight-channel piezoelectric sensor connector PZ-8 and the eDART or CoPilot system. The adapter accepts inputs from any piezoelectric sensor and identifies the connected mold.



SIMILAR PRODUCTS

FOUR-CHANNEL PIEZOELECTRIC SENSOR CONNECTOR PZ-4

The four-channel piezoelectric connector with mold ID PZ-4 (1 at right) is a connector that interfaces up to four piezoelectric sensors with the RJG, Inc. four-channel piezoelectric sensor adapter PZ/LX4F-S-ID and the eDART or CoPilot system.



LYNX™ FOUR-CHANNEL PIEZOELECTRIC SENSOR ADAPTER PZ/LX4F-S-ID

The Lynx four-channel piezoelectric sensor adapter with mold ID PZ/LX4F-S-ID (2 at right) provides a quick, convenient connection between the RJG, Inc. four-channel piezoelectric sensor connector PZ-4 and the eDART or CoPilot system. The adapter accepts inputs from any piezoelectric sensor and identifies the connected mold.



FOUR-CHANNEL PIEZOELECTRIC SENSOR CONNECTOR TO ADAPTER CABLE C-PZ/LX4F-S

The C-PZ/LX4F-S four-channel piezoelectric sensor connector-to-adapter cable (3 at right) is designed for use with the RJG, Inc. four-channel piezoelectric adapter with mold ID PZ/LX4F-S-ID. One C-PZ/LX4F-S is required to interface the PZ-4 with the PZ/LX4F-S-ID and the eDART or CoPilot system.



LOCATIONS / OFFICES

USA

RJG USA (HEADQUARTERS)

3111 Park Drive
Traverse City, MI 49686
P +01 231 947-3111
F +01 231 947-6403
sales@rjginc.com
www.rjginc.com

ITALY

NEXT INNOVATION SRL

Milano, Italy
P +39 335 178 4035
sales@it.rjginc.com
it.rjginc.com

MEXICO

RJG MEXICO

Chihuahua, Mexico
P +52 614 4242281
sales@es.rjginc.com
es.rjginc.com

SINGAPORE

RJG (S.E.A.) PTE LTD

Singapore, Republic of
Singapore
P +65 6846 1518
sales@swg.rjginc.com
en.rjginc.com

FRANCE

RJG FRANCE

Arnithod, France
P +33 384 442 992
sales@fr.rjginc.com
fr.rjginc.com

CHINA

RJG CHINA

Chengdu, China
P +86 28 6201 6816
sales@cn.rjginc.com
zh.rjginc.com

GERMANY

RJG GERMANY

Karlstein, Germany
P +49 (0) 6188 44696 11
sales@de.rjginc.com
de.rjginc.com

KOREA

CAEPRO

Seoul, Korea
P +82 02-2113-1870
sales@ko.rjginc.com
www.caepro.co.kr

IRELAND/UK

RJG TECHNOLOGIES, LTD.

Peterborough, England
P +44(0)1733-232211
info@rjginc.co.uk
www.rjginc.co.uk