

PRODUCT MANUAL

SINGLE/MULTI-CHANNEL
12.6 MM PIEZOELECTRIC CAVITY
PRESSURE SENSOR

9204



PRODUCT MANUAL

SINGLE/MULTI-CHANNEL 12.6 MM PIEZOELECTRIC CAVITY PRESSURE SENSOR

9204

INTRODUCTION

DISCLAIMER	V
PRIVACY	V
ALERTS	V
ABBREVIATIONS	V

PRODUCT DESCRIPTION

APPLICATIONS	1
CAVITY PRESSURE SENSORS	1
SINGLE-CHANNEL	1
MULTI-CHANNEL	1
SENSOR AND EJECTOR PIN SIZE	2
SELECTION CHARTS	2
OPERATION	4
INDIRECT (UNDER-PIN)	4
PIEZOELECTRIC SENSORS	4
DIMENSIONS	5
SENSOR	5
COMPATIBLE CABLES	5
CABLE LENGTHS	5

INSTALLATION

INSTALLATION OVERVIEW	8
CLAMP PLATE (TYPICAL) INSTALLATION	8
CLAMP PLATE (HEAD-TO-HEAD) INSTALLATION	8
EJECTOR PLATE INSTALLATION	9
ANGLED EJECTOR PINS	9
CONTOURED EJECTOR PINS	9

PRODUCT MANUAL

SINGLE/MULTI-CHANNEL 12.6 MM PIEZOELECTRIC CAVITY PRESSURE SENSOR

9204

INSTALLATION (CONTINUED)

INSTALLATION SPECIFICATIONS	10
CLAMP PLATE INSTALLATION	10
CLAMP PLATE (HEAD-TO-HEAD) INSTALLATION	14
COVER PLATE—CLAMP PLATE INSTALLATIONS	18
EJECTOR PLATE INSTALLATION	20
SENSOR STEM AND CABLE CHANNELS	23
SENSOR CABLES	24
SENSOR CABLE RETENTION	25
NON-STANDARD INSTALLATIONS	27
STATIC (NON-MOVING) EJECTOR PINS	27
STATIC (NON-MOVING) EJECTOR PINS	28
MULTIPLE EJECTOR PINS	30
STATIC PIN EXAMPLE	31
STATIC TRANSFER PIN EXAMPLES	32

INSTALLATION VALIDATION

SENSOR INSTALLATION CHECK—CLAMP PLATE (TYPICAL) INSTALLATIONS	33
PRE-ASSEMBLY CHECKS	33
POST-ASSEMBLY CHECKS	35
SENSOR INSTALLATION CHECK—CLAMP PLATE (HEAD-TO-HEAD) INSTALLATIONS	37
PRE-ASSEMBLY CHECKS	37
POST-ASSEMBLY CHECKS	39
SENSOR INSTALLATION CHECK—EJECTOR PLATE INSTALLATIONS	41
PRE-ASSEMBLY CHECKS	41
POST-ASSEMBLY CHECK	41
SENSOR INSTALLATION CHECK—STATIC PIN INSTALLATIONS	42

PRODUCT MANUAL

SINGLE/MULTI-CHANNEL 12.6 MM PIEZOELECTRIC CAVITY PRESSURE SENSOR

9204

MAINTENANCE

CLEANING & DRIFT	43
REGULAR CLEANING	43
DRIFT	43
TESTING & CALIBRATION	43
SENSOR TESTING	43
WARRANTY	44
RJG, INC. STANDARD THREE-YEAR WARRANTY	44
PRODUCT DISCLAIMER	44

TROUBLESHOOTING

INSTALLATION ERRORS	45
EJECTOR PIN ISSUES	45
SENSOR HEAD ISSUES	46
CASE AND CABLE ISSUES	47
COMMON ERRORS	48
SLOW SENSOR DRIFT READING	49
FAST SENSOR DRIFT/INVALID READING	50
SENSOR DOES NOT COMMUNICATE WITH EDART	51
CUSTOMER SUPPORT	52

PRODUCT MANUAL

SINGLE/MULTI-CHANNEL 12.6 MM PIEZOELECTRIC CAVITY PRESSURE SENSOR

9204

RELATED PRODUCTS

COMPATIBLE PRODUCTS	53
LYNX CABLES CE-LX5	53
SINGLE-CHANNEL PIEZOELECTRIC SENSOR CABLE 1645	53
MULTI-CHANNEL PIEZOELECTRIC SENSOR CABLE C-PZ/1645	53
SIMILAR PRODUCTS	54
LYNX SINGLE-CHANNEL STRAIN GAGE BUTTON SENSOR LS-B-127-50/125/500/2000	54
SINGLE/MULTI-CHANNEL 3.5 MM PIEZOELECTRIC SENSOR 9210	54
SINGLE/MULTI-CHANNEL 6 MM PIEZOELECTRIC SENSOR 9211	54

INTRODUCTION

Read, understand, and comply with all following instructions. This guide must be kept available for reference at all times.

DISCLAIMER



Inasmuch as RJG, Inc. has no control over the use to which others may put this material, it does not guarantee that the same results as those described herein will be obtained. Nor does RJG, Inc. guarantee the effectiveness or safety of any possible or suggested design for articles of manufacture as illustrated herein by any photographs, technical drawings, and the like. Each user of the material or design or both should make his own tests to determine the suitability of the material or any material for the design as well as the suitability of the material, process, and/or design for his own particular use. Statements concerning possible or suggested uses of the material or designs described herein are not to be construed as constituting a license under any RJG, Inc. patent covering such use or as recommendations for use of such material or designs in the infringement of any patent.

PRIVACY

Designed and developed by RJG, Inc. Manual design, format and structure copyright 2021 RJG, Inc. content documentation copyright 2021 RJG, Inc. All rights reserved. Material contained herein may not be copied by hand, mechanical, or electronic means, either whole or in part, without the express written consent of RJG, Inc. Permission will normally be granted for use in conjunction with inter-company use not in conflict with RJG's best interests.

ALERTS

The following three alert types are used as needed to further clarify or highlight information presented in the manual:

-  **DEFINITION** *A definition or clarification of a term or terms used in the text.*
-  **NOTES** *A note provides additional information about a discussion topic.*
-  **CAUTION** *A caution is used to make the operator aware of conditions that can cause damage to equipment and/or injury to personnel.*

ABBREVIATIONS

DIA	diameter
MIN	minimum
MAX	maximum
R.	radius

PRODUCT DESCRIPTION

The 9204 single- or multi-channel sensor is a 12,6 mm (0.496”) digital, indirect (under-pin), button-style, piezoelectric cavity pressure sensor designed for use with the RJG eDART® process control and monitoring system. The 9204 boasts a 2,248 lb. (10,0 kN) capacity and a sensitivity rating of 9.80 pC/lb. (2,2 pC/kN) with a maximum temperature rating of 392 °F (200 °C).

The button-style sensor can be connected to either a single- or multi-channel cable (sold separately) which connects the sensor head to the sensor single- or multi-channel plate/adaptor (also sold separately). The plate/adaptor selected provides not only the sensor’s electronics, but also the connector which enables the interfacing of the sensor with the eDART system; the exclusive Lynx™ digital technology sensors are designed for use with the RJG eDART process control and monitoring system.

APPLICATIONS

CAVITY PRESSURE SENSORS

Button-style cavity pressure sensors are suitable for injection molding applications in which the following conditions are met:

- Sensor will be installed behind an ejector pin, blade, or core pin.
- Applied plastic pressure is high enough to prevent poor sensor resolution, but low enough to prevent sensor damage.
- Sensor will be kept below 392 °F (200 °C) in the mold; sensor electronics will be kept below 140 °F (60 °C).
- Only one point of contact (single pin) to each sensor.



SINGLE-CHANNEL

The 9204 sensor can be utilized in single-channel applications in conjunction with the Lynx mold-mount piezoelectric sensor adapter LP/LX1-M or the Lynx surface-mount piezoelectric sensor adapter PZ/LX1-S and the eDART system.

MULTI-CHANNEL

The 9204 sensor can be utilized in multi-channel applications which enable either four or eight sensors to be connected outside the mold with a single cable. The Lynx four-channel piezoelectric sensor connector and adapter—PZ-4 and PZ/LX4F-S—allows up to four sensor connections, while the Lynx eight-channel piezoelectric sensor connector and adapter—PZ-8 and PZ/LX8F-S—allow up to eight sensor connections to the eDART system.

SENSOR AND EJECTOR PIN SIZE

SELECTION CHARTS

Locate the pin size that will be used and match it to the location on the part (near the end of fill or near the gate). The recommended sensor is the intersection of the row and column.

RJG® recommends that expected peak force is less than or equal to 75% of the sensor model's full scale. The expected peak force can be determined by multiplying the expected peak plastic pressure at the sensor's pin location by the project surface area of the pin on the cavity wall—this is recommended for each sensor location in an instrumented tool. The expected peak plastic pressure can be found from simulation or similar processes, or estimated from the material tonnage on the material safety data sheet (MSDS).

The charts below are only a guide. In order to assure correct sensor selection for an application, please contact RJG.

1. Imperial Units

Pin Size	END OF FILL AREA BASE PRESSURE	POST GATE AREA BASE PRESSURE
	>5,000 PSI	10,000 PSI
3/32	-	9204
7/64	-	9204
1/8	9204	9204
9/64	9204	9204
5/32	9204	9204
3/16	9204	9204
7/32	9204	9204
1/4	9204	9204
9/32	9204	9204
5/16	9204	9204
11/32	9204	9204
3/8	9204	9204
13/32	9204	9204
7/16	9204	9204
1/2	9204	-
9/16	9204	-
5/8	9204	-

SENSOR AND EJECTOR PIN SIZE (continued)

2. Metric Units

Pin Size	END OF FILL AREA BASE PRESSURE >5,000 PSI	POST GATE AREA BASE PRESSURE 10,000 PSI
2.5 mm	-	9204
3.0 mm	-	9204
3.5 mm	9204	9204
4.0 mm	9204	9204
4.5 mm	9204	9204
5.0 mm	9204	9204
5.5 mm	9204	9204
6.0 mm	9204	9204
6.5 mm	9204	9204
7.0 mm	9204	9204
7.5 mm	9204	9204
8.0 mm	9204	9204
8.5 mm	9204	9204
9.0 mm	9204	9204
9.5 mm	9204	9204
10.0 mm	9204	9204
11.0 mm	9204	9204
12.0 mm	9204	-
13.0 mm	9204	-
14.0 mm	9204	-
15.0 mm	9204	-
13.0 mm	9204	-
14.0 mm	9204	-
15.0 mm	9204	-
16.0 mm	9204	-
17.00 mm	9204	-

OPERATION

INDIRECT (UNDER-PIN)

The single/multi-channel piezoelectric sensor is placed in a mold behind an ejector pin. As plastic is injected into the cavity, force is applied to the ejector pin. The plastic pressure force is transferred to the sensor.

PIEZOELECTRIC SENSORS

Piezoelectric sensors use quartz crystals to measure the deformation, or change in resistance of the force over the sensor. The measurement is carried through the sensor cable to a sensor adapter mounted on the outside of the mold.

Piezoelectric quartz crystals contain balanced negative and positive electrical charges which are not symmetrically arranged. When force is applied to the piezoelectric crystal, the positive and negative atoms are deformed, pushing some of the atoms closer or further apart and causing electrical charges to occur.

The sensor adapter is connected to the RJG, Inc. eDART system, which records and displays the sensor's measurement for operator aid in process monitoring and control.

PIEZOELECTRIC SENSOR OPERATING PRINCIPLE

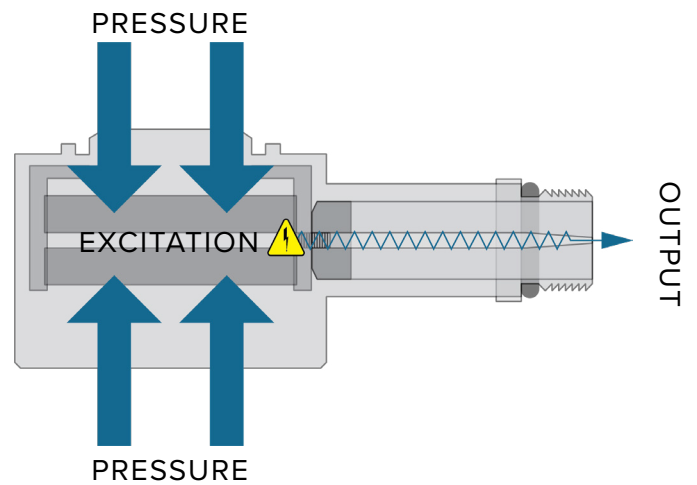

DIMENSIONS

SENSOR

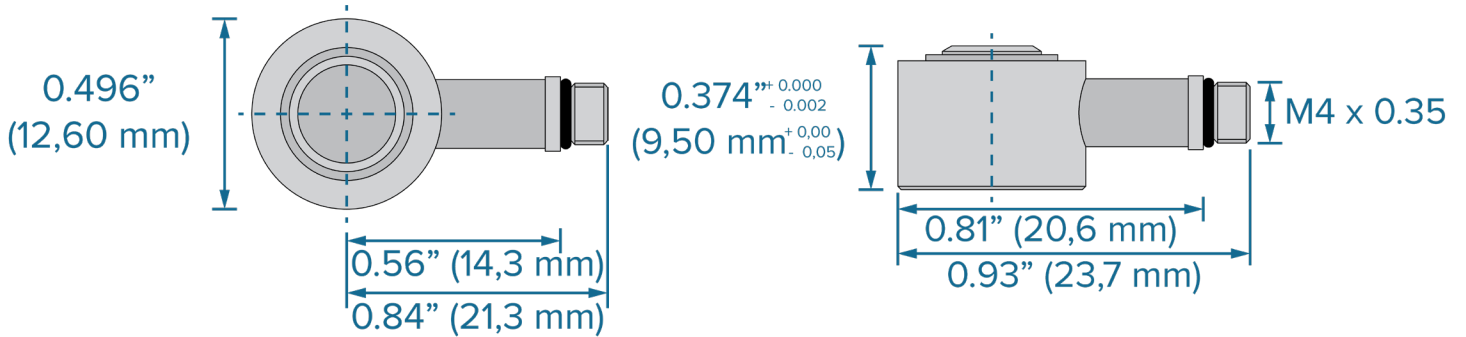

COMPATIBLE CABLES

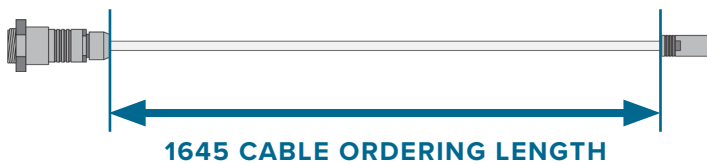

CABLE LENGTHS

Length must be longer than needed to facilitate safe installation and removal of connector from tool to prevent tension on the lead wire; generally, 2–3" (50–75 mm) of slack is sufficient. Use good sense to determine the appropriate cable length required for each application.

	SINGLE-CHANNEL	MULTI-CHANNEL	LENGTH	
			S.I.	ENGLISH
-		C-PZ/1645-0.1	0,1 m	3.9"
-		C-PZ/1645-0.15	0,15 m	5.9"
1645-0.2		C-PZ/1645-0.2	0,2 m	7.90"
-		C-PZ/1645-0.25	0,25 m	9.8"
-		C-PZ/1645-0.3	0,3 m	11.8"
-		C-PZ/1645-0.35	0,35 m	13.8"
1645-0.4		C-PZ/1645-0.4	0,4 m	15.75"
1645-0.6		C-PZ/1645-0.6	0,6 m	23.60"
1645-0.8		C-PZ/1645-0.8	0,8 m	31.50"
1645-1.2		C-PZ/1645-1.2	1,2 m	47.24"
1645-1.6		C-PZ/1645-1.6	1,6 m	62.99"
1645-2.0		C-PZ/1645-2.0	2,0 m	78.74"

INSTALLATION

Sensors may be placed in the clamp plate behind transfer pins, or in the ejector plate behind ejector pins. Installation location—in the clamp plate or ejector plate—depends upon mold real estate and customer preference.

Transfer pins protect the sensor from damaging shock loads that are applied when the ejector plate moves forward and backward; the sensor's cable is also protected from pinching since it is not necessary to disassemble the clamp and backing plates during normal usage or preventative maintenance.

Ejector pins provide a simple, straightforward method of installation in which sensors may be installed; ejector pin installation requires less machining and less equipment to achieve.

CLAMP PLATE INSTALLATIONS

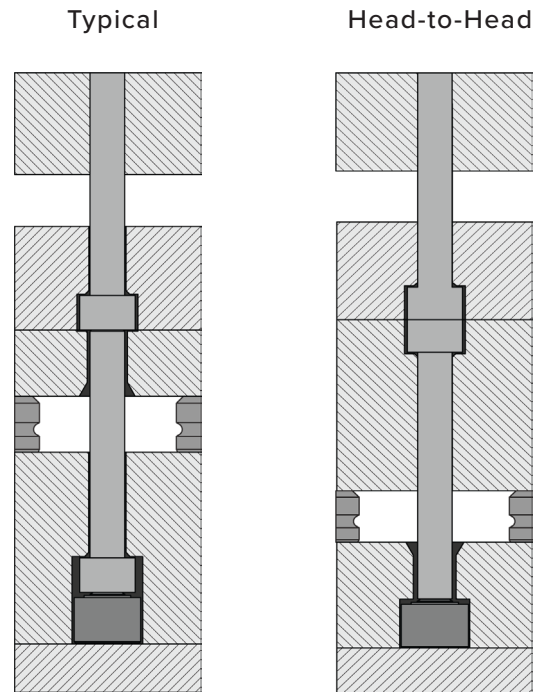

EJECTOR PLATE INSTALLATION

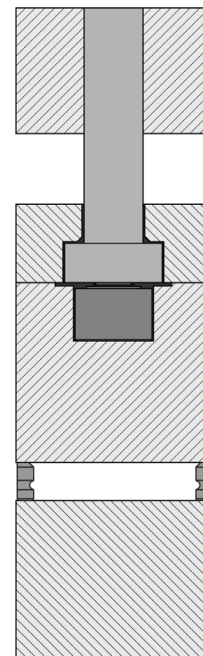

INSTALLATION OVERVIEW

CLAMP PLATE (TYPICAL) INSTALLATION

Apply the clamp plate (typical) installation to instances where the ejector and transfer pins are less than 0.28" (7,0 mm) in diameter.

The sensor connector plate is mounted on the mold. Pockets and a channel is machined into the mold for the sensor connector, cable, and sensor head. The sensor head is placed under the transfer pin above the cover plate in the clamp plate. The transfer pin is retained below the ejector pin in the clamp plate. The ejector pin is retained in the ejector retainer plate and reaches through to the B-Plate or cavity insert (refer to figure at top right).

A minimum of 0.50" (12,0 mm) or one-third of the transfer pins length, whichever is greater, must be fitted to a H7/g6 tolerance within the clamp plate to ensure proper pin alignment and to prevent possible bending. If 0.50" (12,0 mm)/one-third minimum cannot be achieved, apply the head-to-head clamp plate installation concept (refer to figure at top right).

CLAMP PLATE (HEAD-TO-HEAD) INSTALLATION

Apply the clamp plate (head-to-head) installation to instances where the ejector and transfer pins are greater than 0.28" (7,0 mm) in diameter, or those in which a minimum of 0.50" (12,0 mm)/one-third of the transfer pin cannot be contained above the transfer pin head in the clamp plate.

The sensor connector plate is mounted on the mold. Pockets and a channel is machined into the mold for the sensor connector, cable, and sensor head. The sensor head is placed under the transfer pin above the cover plate in the clamp plate. The transfer pin is retained below the ejector pin in the ejector plate, while the ejector pin is retained in the ejector retainer plate, with both heads resting against each other. The ejector pin reaches through to the B-Plate or cavity insert (refer to figure at bottom right).

CLAMP PLATE (TYPICAL) INSTALLATION

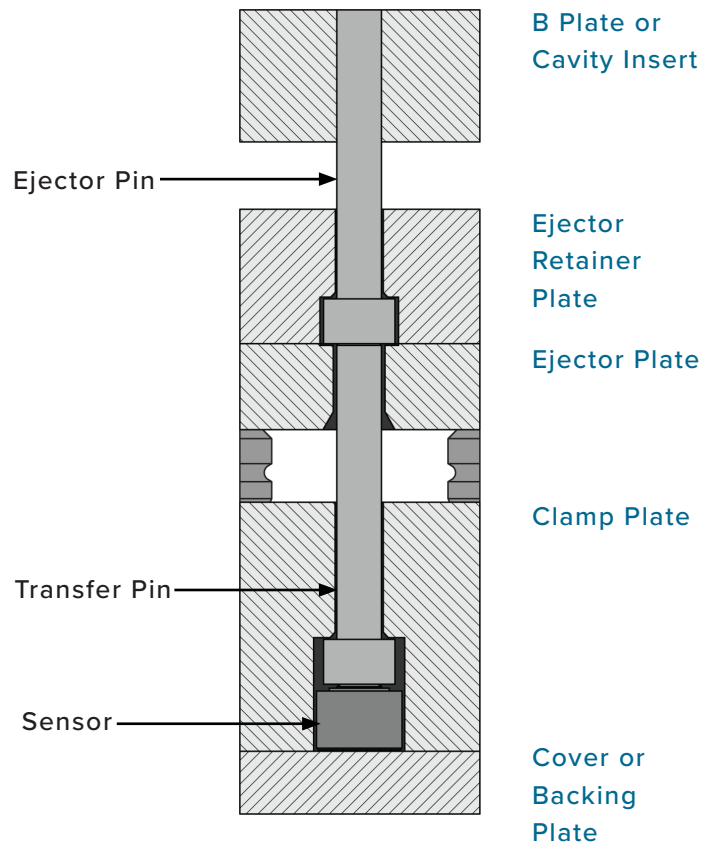

CLAMP PLATE (HEAD-TO-HEAD) INSTALLATION

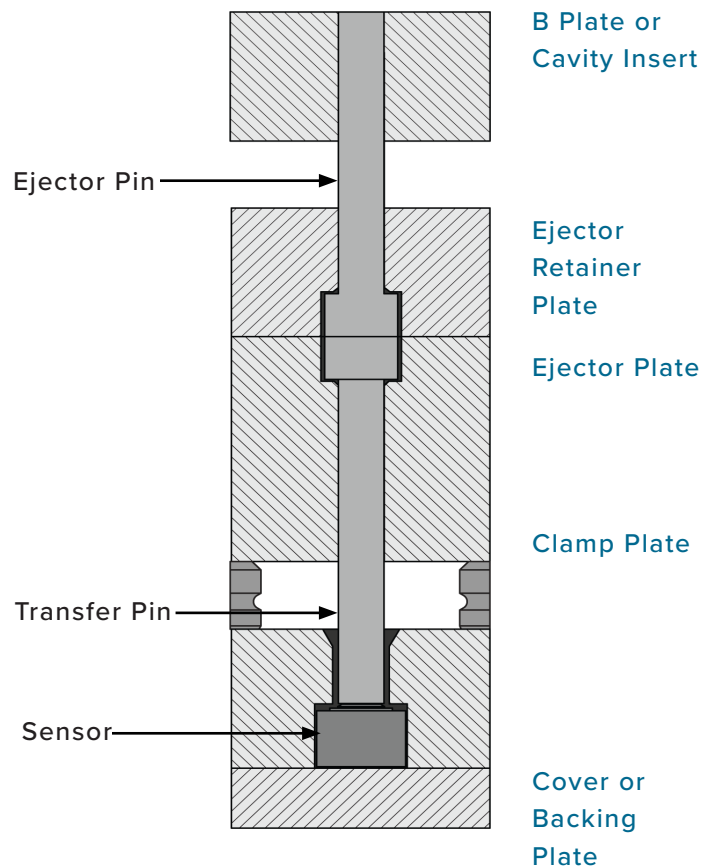

INSTALLATION OVERVIEW (continued)

EJECTOR PLATE INSTALLATION

The sensor connector plate is mounted on the mold. Pockets and a channel is machined into the mold for the sensor connector, cable, and sensor head. The sensor head is placed under the ejector pin in the ejector plate. The ejector pin is retained in the ejector retainer plate and reaches through to the B-Plate or cavity insert (refer to figure at right).

ANGLED EJECTOR PINS

Ejector pins that are located on angled surfaces of a part can utilize sensors depending on the angle of the pin. The maximum pin angle that can be used with sensors is 30° (1 at right). Beyond 30°, force is lost to friction as the pin is pushed sideways against the mold steel instead of directly back onto the sensor, which in turn can create errors in sensor readings. If the angle is greater than 30°, contact RJG customer support for assistance in verifying suitability for use with an RJG sensor (refer to “Customer Support” on page 55).

CONTOURED EJECTOR PINS

Ejector pins that are located on contoured surfaces of a part can be used on either concave and convex surfaces (2 at right) provided the shape of the contour is symmetric, as this cancels out any sideways forces generated by cavity pressure pushing on the pin.

Do not use an asymmetrically-contoured ejector pin if the net contour is greater than a comparable pin with a 30° angle. If a contour is unique or asymmetrical, contact RJG customer support for assistance in verifying suitability for use with an RJG sensor (refer to “Customer Support” on page 55).

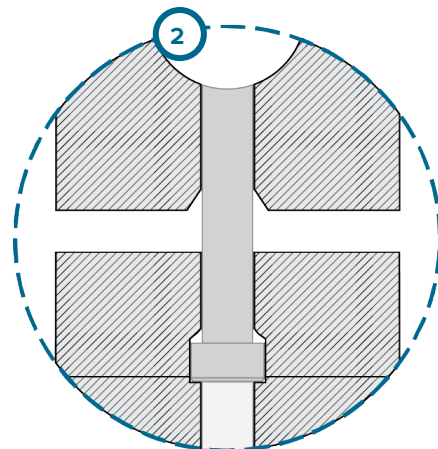
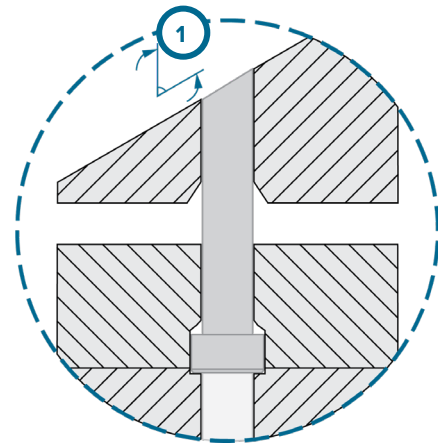
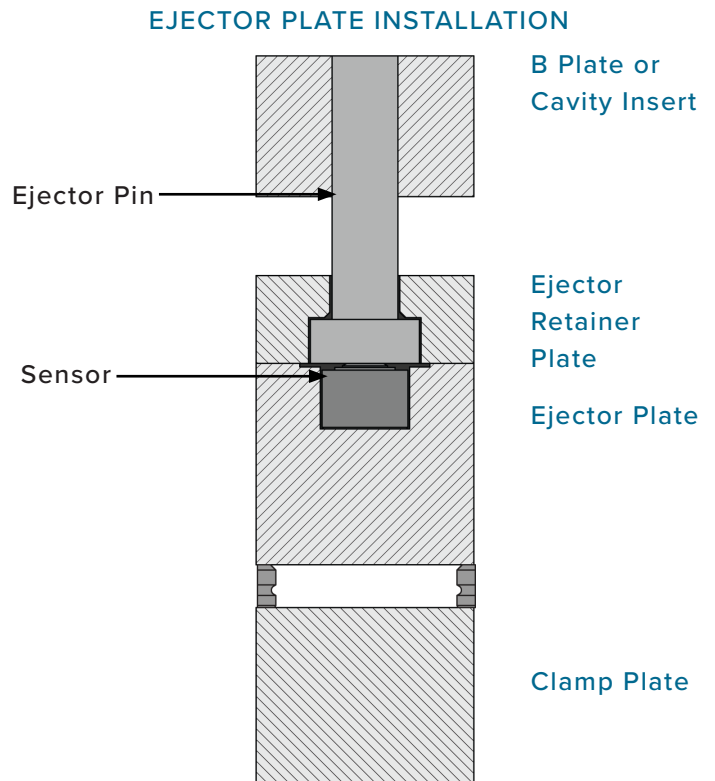

INSTALLATION SPECIFICATIONS

CLAMP PLATE INSTALLATION

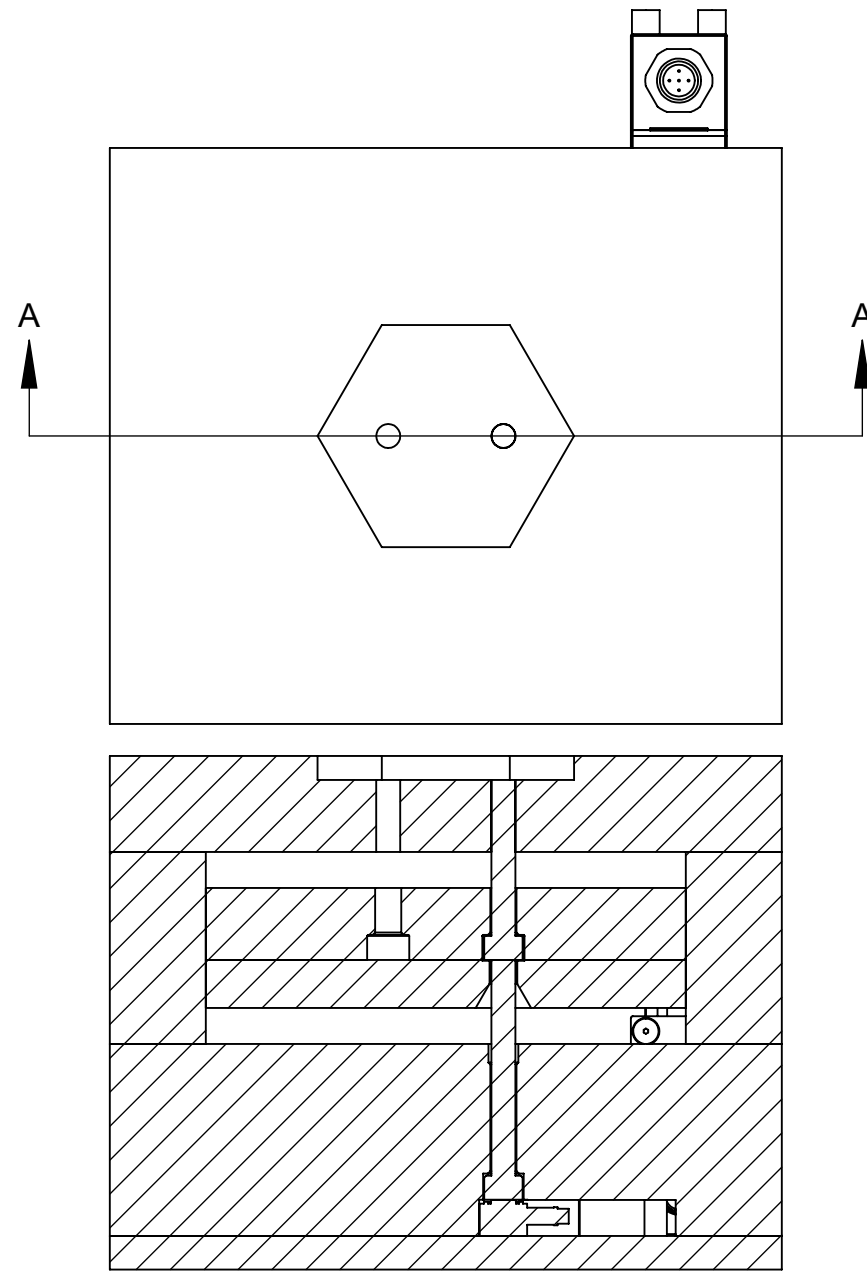

SECTION A-A
SCALE 1 : 2

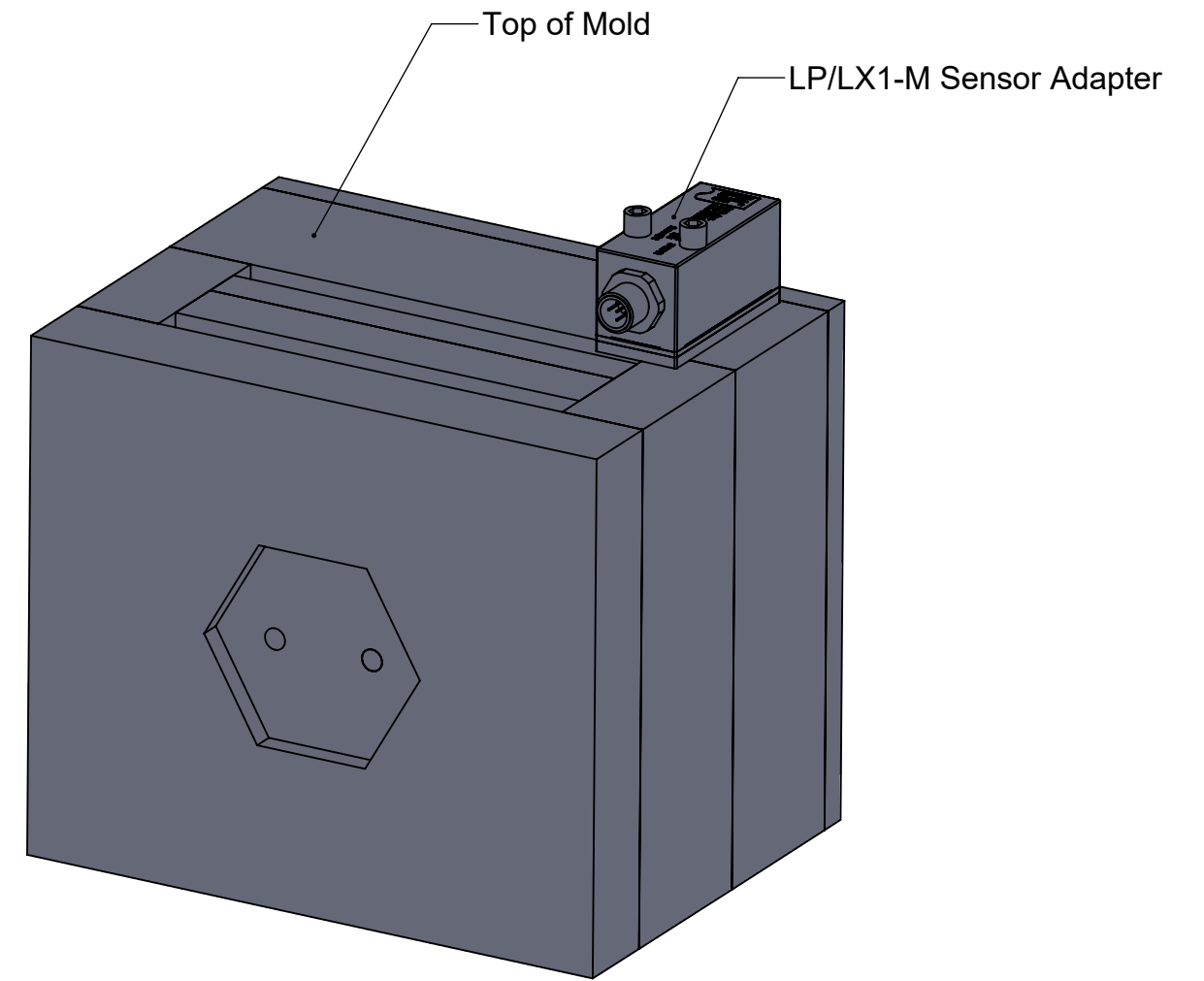
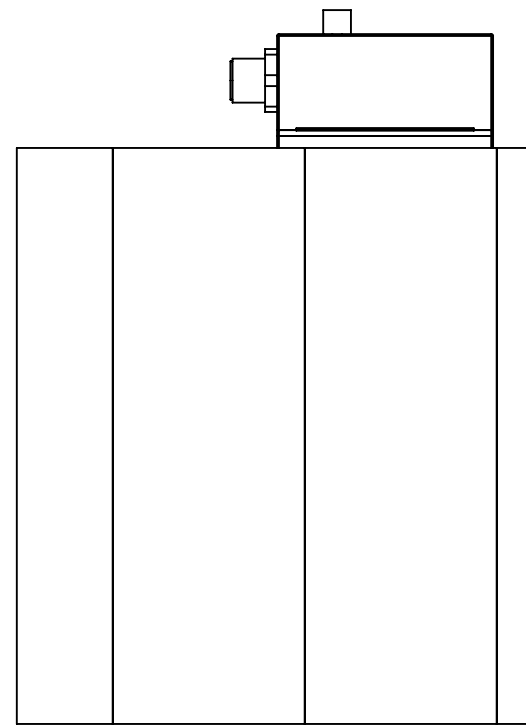

CLAMP PLATE INSTALLATION

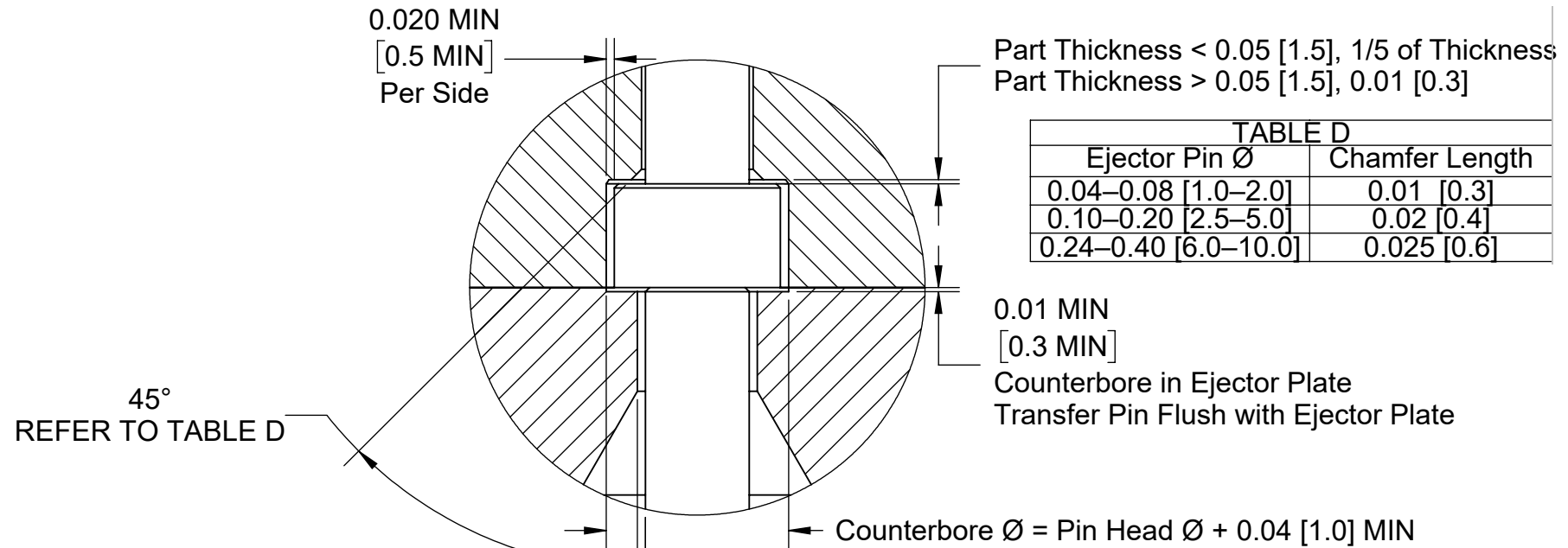
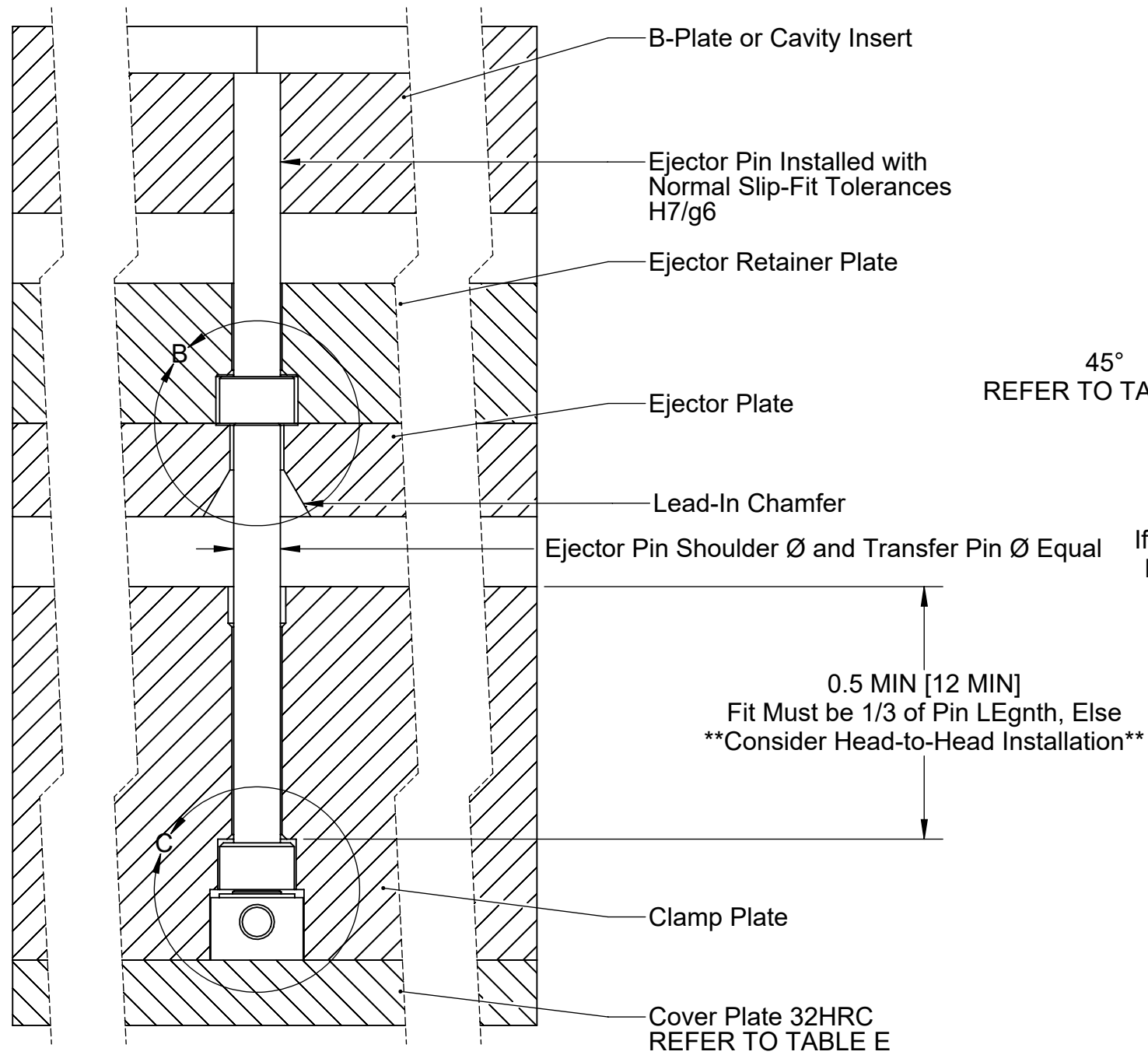

Ejector Pin \varnothing	Chamfer Length
0.04–0.08 [1.0–2.0]	0.01 [0.3]
0.10–0.20 [2.5–5.0]	0.02 [0.4]
0.24–0.40 [6.0–10.0]	0.025 [0.6]

If Pin \varnothing < 0.12 [3.0], \varnothing + 0.04 [1.0]
 If Pin \varnothing > 0.12 [3.0], + 0.06 [1.5]

	0.001 [0.03]	F
	0.001 [0.03]	

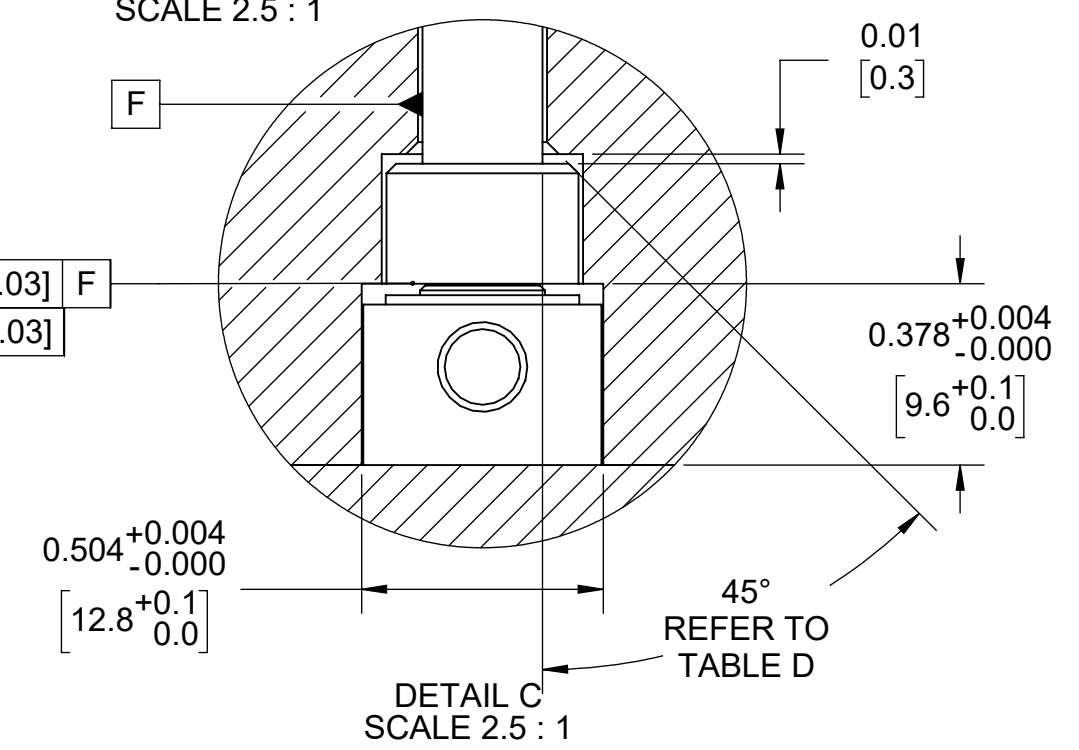

Pin \varnothing	MIN Plate Thickness
3/32–7/64" [2.5–3.0]	0.2 [5]
9/64"–5/8" [14.0–23.0]	0.25 [6.0]

INSTALLATION SPECIFICATIONS (continued)

3. Sensor Head Pocket

Sensor and transfer pin head pockets are machined into the clamp plate. The sensor pockets must be centered under the selected ejector pin measuring 0.504" +0.004/-0.0 (12,8 mm +0,1/-0,0 [1 at right]) DIA, and 0.378" +0.004/-0.0 (9,6 mm +0,1/-0,0 [2 at right]) deep.

4. Transfer Pin Head Pocket

Choose an ejector and transfer pin appropriate for the application (refer to "Sensor and Ejector Pin Size" on page 2). Ejector and transfer pin must be concentric within 0.030" (0,76 mm) or 10% of ejector pin diameter—whichever is smaller. Ejector and transfer pin diameter 0.25" (7,0 mm) MAX, and must be equal in diameter.

Transfer pin head pockets must be centered under the selected ejector pin measuring the transfer pin head height plus a clearance of 0.01" (0,3 mm [3 at right]) MIN. Chamfer the transfer pin head pocket at 45° (4 at right) to the lead-in of clamp plate, and fit the pin with an H7/g6 fit (5 1 at right) for at least 0.50" (12,0 mm) MIN.

Chamfer the lead-in at 30° (6 at right) to the ejector plate for a depth which equals the transfer pin DIA, and provide clearance for the transfer pin in the ejector plate equal to pin DIA plus 0.04" (1,0 mm) if pin DIA is < 0.12" (3,0 mm), or 0.06" (1,5 mm) if pin DIA is > 0.12" (3,0 mm). Transfer pin must be 0.01" (0,3 mm) longer than nominal for initial fit, then adjusted to obtain the correct height.

CLAMP PLATE (TYPICAL) INSTALLATION

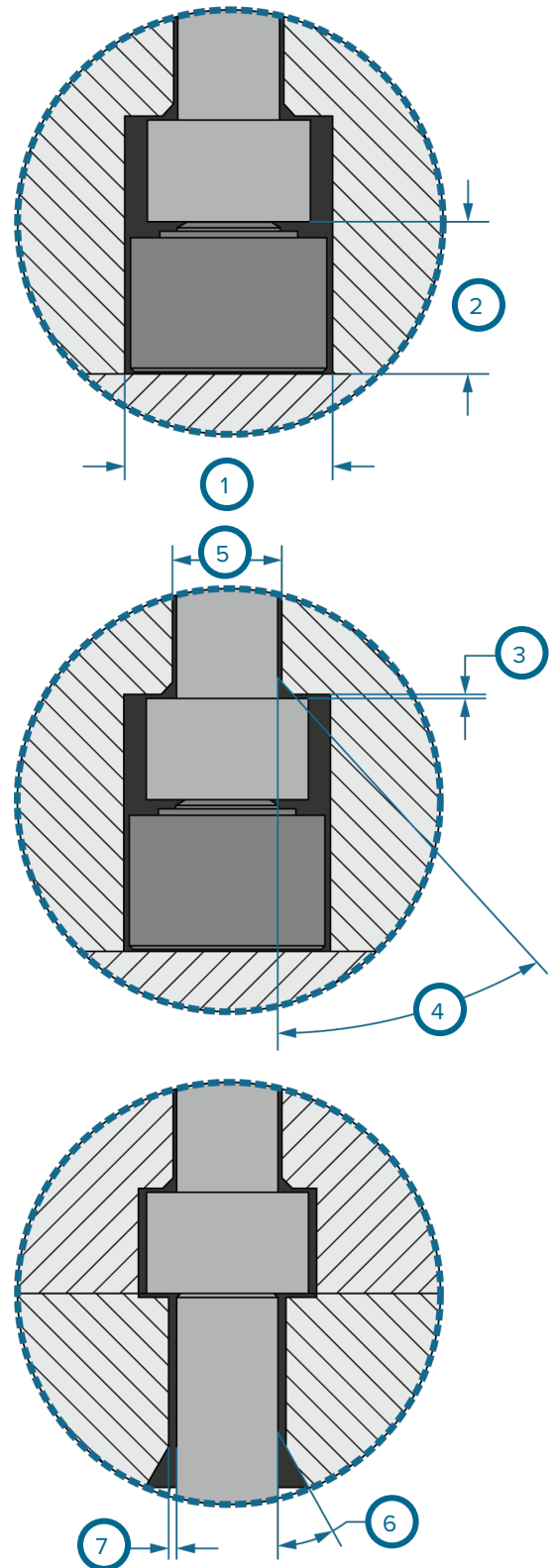

NOTES There must be 0.50" (12,0 mm) MIN clamp plate thickness above the transfer pin head to transfer pin cleared exit, equaling 1/3 of the pin length; if 1/3 pin length not possible in clamp plate thickness, use head-to-head concept on page 10.

1 0.504" +0.004/-0.0 (12,8 mm +0,1/-0,0) DIA

2 0.378" +0.004/-0.0 (9,6 mm +0,1/-0,0)

3 0.01" (0,3 mm) MIN

4 45° Chamfer

5 H7/g6 for 0.50" (12,0 mm) MIN 1

6 30° Chamfer, Depth=Pin DIA

7 If Pin DIA < 0.12" (3,0 mm), + 0.04" (1,0 mm)
If Pin DIA > 0.12" (3,0 mm), + 0.06" (1,5 mm)

INSTALLATION SPECIFICATIONS *(continued)*

5. Ejector Pin Head Pocket

Machine a pocket for the ejector pin head in the ejector retainer plate that is equal to the ejector pin head DIA plus 0.02" (0,5 mm [1 at right]) MIN per side.

Allow clearance above the ejector pin head. If the part thickness is < 0.05" (1,5 mm), the clearance should equal 20% of the part thickness. If the part thickness is > 0.05" (1,5 mm), the clearance should equal 0.01" (0,3 mm [2 1 at right]).

NOTES Ejector pin head clearance not to exceed 20% (1/5th) of part thickness at point of pin/part convergence.

Chamfer the lead-in edge 45° (3 at right)—refer to the following table for chamfer length.

CHAMFER LENGTH

Ejector Pin DIA	Chamfer Length
0.04–0.08 (1,0–2,0 mm)	0.01 (0,3 mm)
0.10–0.20 (2,5–5,0 mm)	0.02 (0,4 mm)
0.24–0.40 (6,0–10,0 mm)	0.025 (0,6 mm)

Fit the ejector pin with an H7/g6 standard fit (4 at right).

Counterbore the ejector pin head pocket into the ejector plate 0.01" (0,3 mm [5 at right]) MIN deep, by ejector pin head DIA + 0.04" (1,0 mm [6 at right]).

CLAMP PLATE (TYPICAL) INSTALLATION

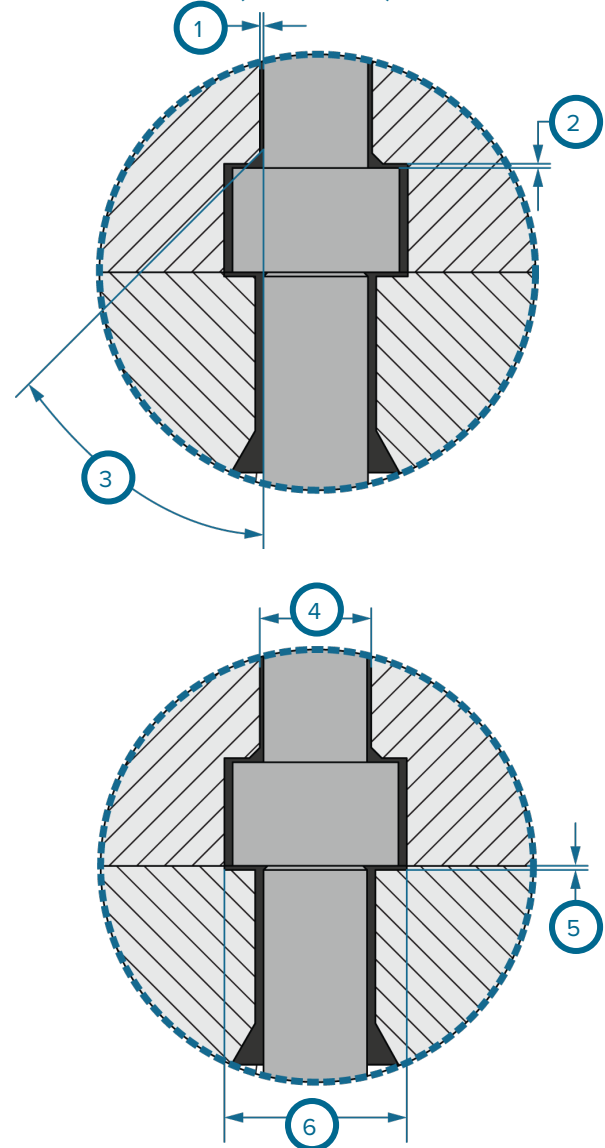

CAUTION Transfer pin applications require guided ejection; failure to comply may result in damage to or destruction of components.

1	0.02" (0,5 mm) MIN per side
2	20% part thickness if < 0.05" (1,5 mm), 0.01" (0,3 mm) if part thickness > 0.05" (1,5 mm) 1
3	45° Chamfer, refer to table for chamfer length
4	H7/g6 standard fit
5	0.01" (0,3 mm) MIN
6	ejector pin head DIA + 0.04" (1,0 mm)

INSTALLATION SPECIFICATIONS (continued)

CLAMP PLATE (HEAD-TO-HEAD) INSTALLATION

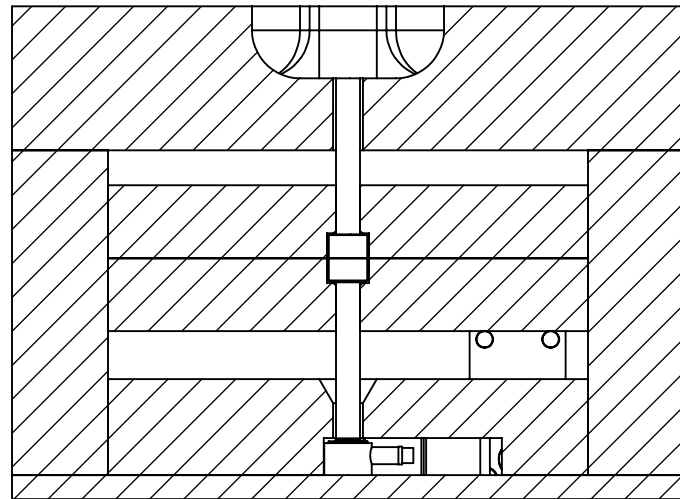
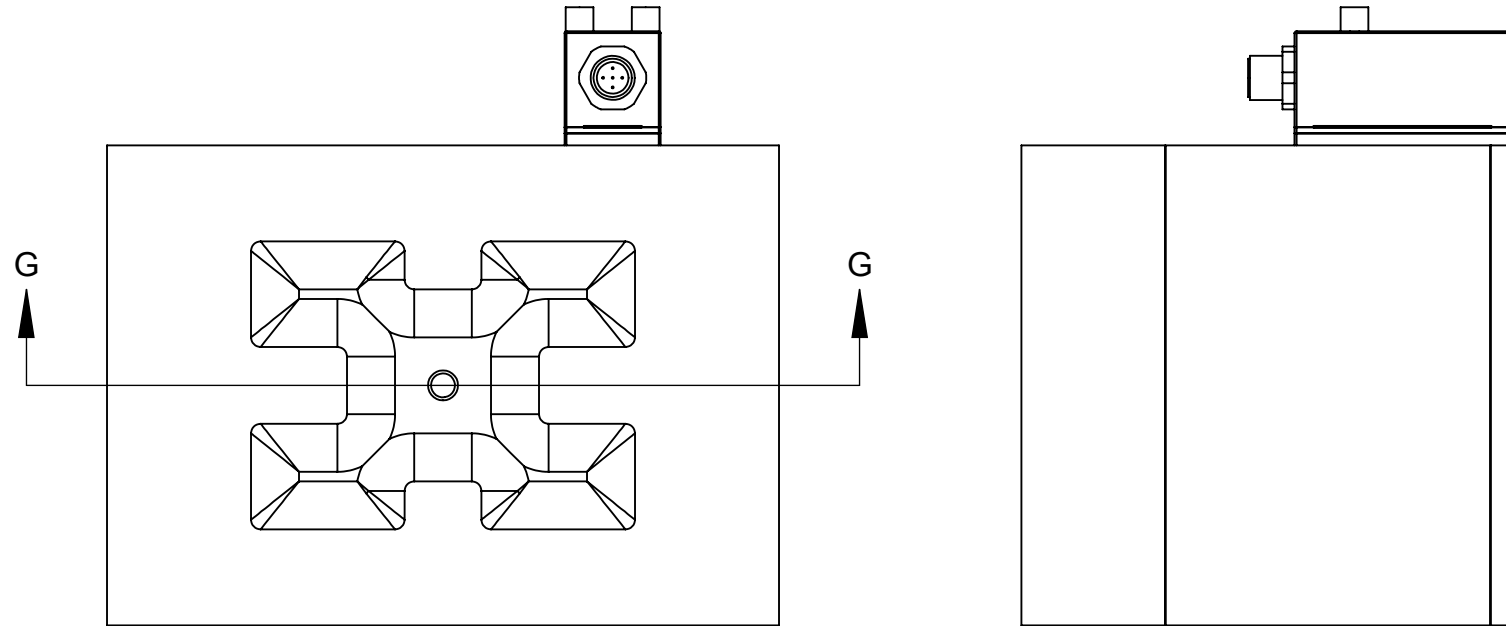

SECTION G-G
SCALE 1 : 2

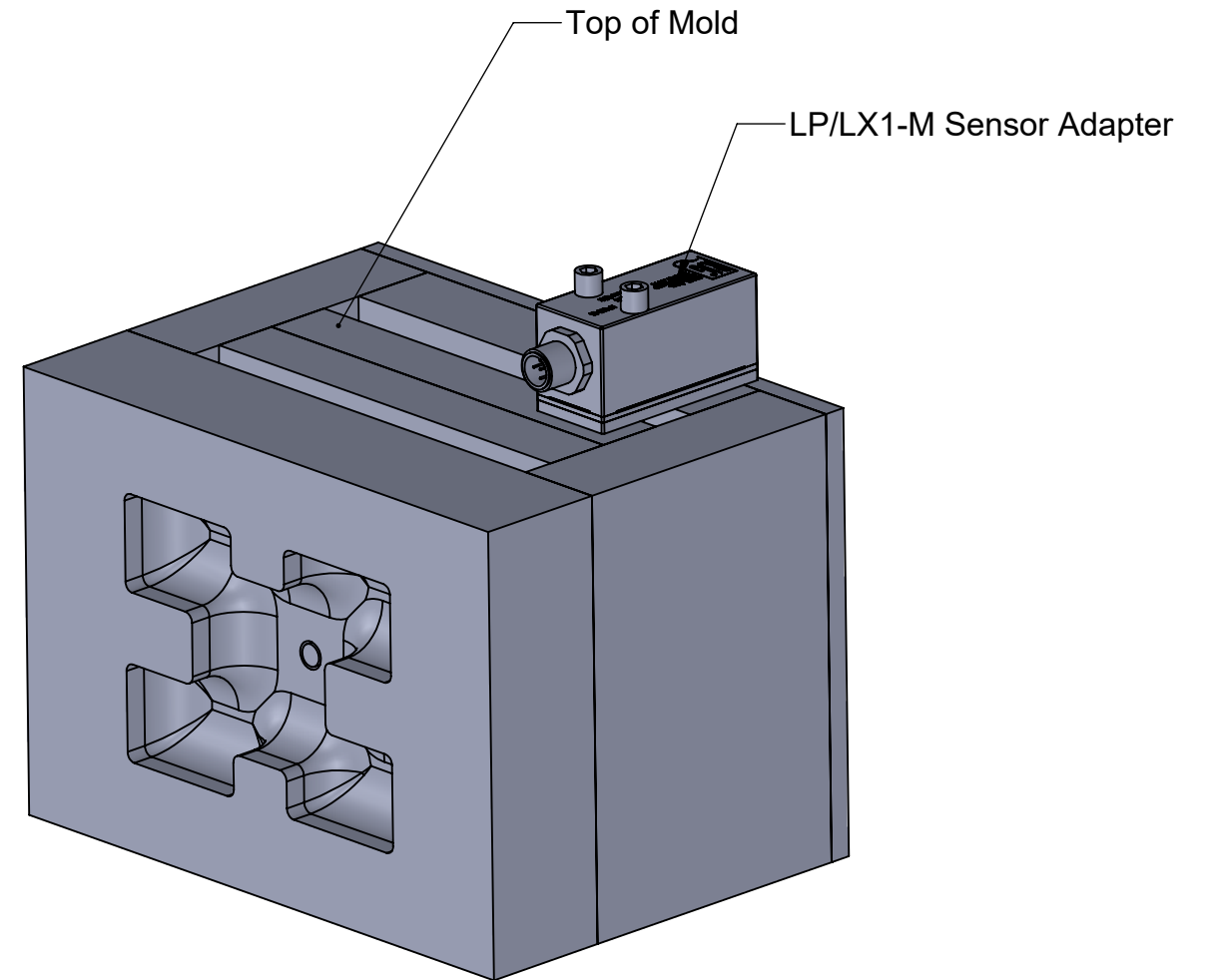

CLAMP PLATE (HEAD-TO-HEAD) INSTALLATION

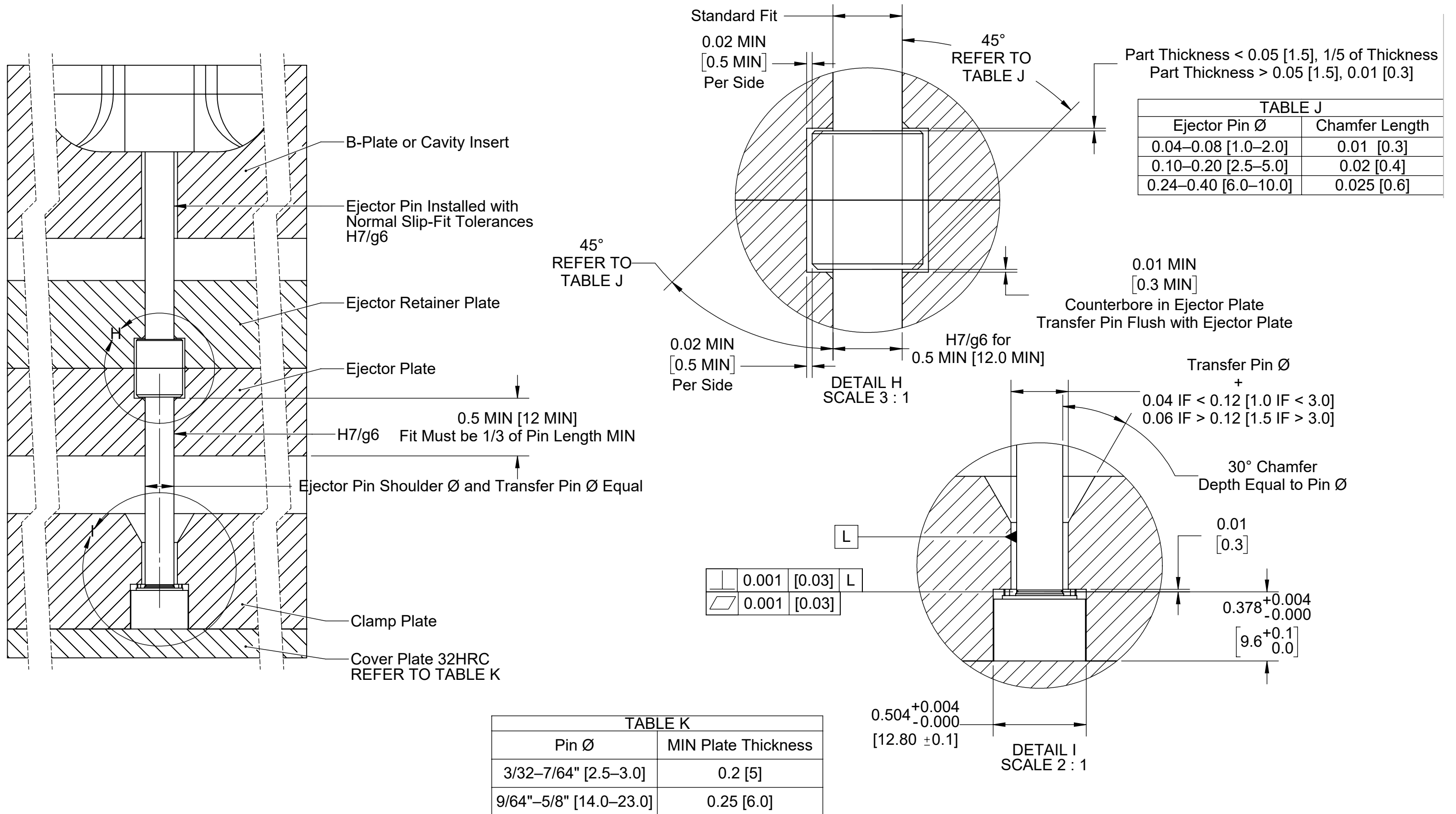

1. Sensor Head Pocket

Sensor head pockets are machined into the clamp plate. The sensor pockets must be centered under the selected ejector pin measuring 0.504" +0.004/-0.0 (12,8 mm +0,1/-0,0 [1 at right]) DIA, and 0.378" +0.004/-0.0 (9,6 mm +0,1/-0,0 [2 at right]) deep, with an added clearance of 0.01" (0,3 mm [3 at right]) MIN above the sensor head.

2. Transfer Pin Shaft Pocket

Choose an ejector and transfer pin appropriate for the application (refer to "Sensor and Ejector Pin Size" on page 2). Ejector and transfer pin must be concentric within 0.030" (0,76 mm) or 10% of ejector pin diameter—whichever is smaller. Ejector and transfer pin must be equal in diameter.

Transfer pin pockets must be centered under the selected ejector pin.

Machine a pocket for the transfer pin shaft from the sensor head pocket through the clamp plate equaling the transfer pin DIA plus 0.04" (1,0 mm) if pin DIA is < 0.12" (3,0 mm) DIA, or 0.06" (1,5 mm) if pin DIA is > 0.12" (3,0 mm [4 at right]).

Chamfer the transfer pin head pocket at 30° (5 at right) for a depth equal to the pin diameter at exit of clamp plate.

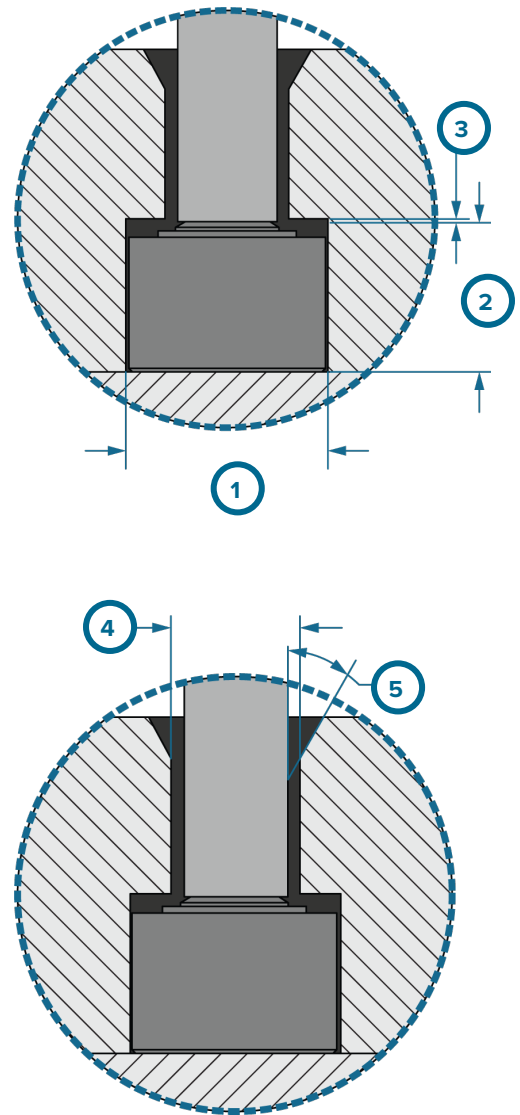

1	0.504" +0.004/-0.0 (12,8 mm +0,1/-0,0) DIA
2	0.378" +0.004/-0.0 (9,6 mm +0,1/-0,0)
3	0.01" (0,3 mm) MIN
4	transfer pin DIA + 0.04" (1,0 mm) if < 0.12" (3,0 mm), OR + 0.06" (1,5 mm) if > 0.12" (3,0 mm)
5	30° Chamfer, Depth = Pin DIA

3. Transfer Pin Shaft and Head Pocket

Machine a pocket for the transfer pin shaft in the ejector plate with an H7/g6 fit for 0.5" (12 mm [1 at right]) MIN.

Machine a pocket for the transfer pin head in the ejector plate that is equal to the transfer pin head DIA plus 0.02" (0,5 mm [2 at right]) MIN per side. Allow 0.01" (0,3 mm [3 at right]) MIN clearance below pin head. Chamfer the transfer pin head pocket at 45° (4 at right).

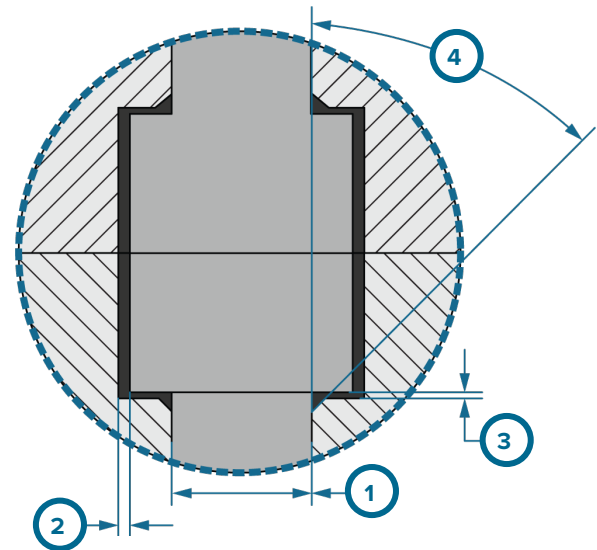

4. Ejector Pin Head Pocket

Machine a pocket for the ejector pin head in the ejector retainer plate that is equal to the ejector pin head DIA plus 0.02" (0,5 mm [5 at right]) MIN per side.

Allow clearance above the ejector pin head. If the part thickness is < 0.05" (1,5 mm), the clearance should equal 20% of the part thickness. If the part thickness is > 0.05" (1,5 mm), the clearance should equal 0.01" (0,3 mm [6 I at right]).

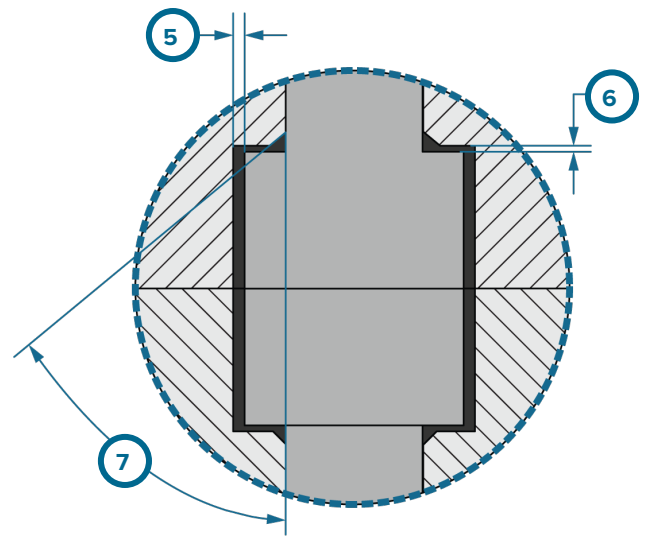

NOTES Ejector pin head clearance not to exceed 20% (1/5th) of part thickness at point of pin/part convergence.

Chamfer the lead-in edge 45° (7 at right).

CAUTION Transfer pin applications require guided ejection; failure to comply may result in damage to or destruction of components.

1	H7/g6 for 0.5" (12 mm) MIN
2	0.02" (0,5 mm) MIN per side
3	0.01" (0,3 mm) MIN
4	45° Chamfer, refer to TABLE J on page 15
5	0.02" (0,5 mm) MIN per side
6	20% part thickness if < 0.05" (1,5 mm), 0.01" (0,3 mm) if part thickness > 0.05" (1,5 mm) I
7	45° Chamfer, refer to TABLE J on page 15

INSTALLATION SPECIFICATIONS *(continued)*

COVER PLATE—CLAMP PLATE INSTALLATIONS

The cover plate must be made of SAE 1080 steel (AFNOR XC70/XC80), 32HRC. The cover plate may be an additional, whole plate added to the stack and secured with screws (**BELOW, LEFT**), or an integrated plate made to embed into the clamp plate and secured with screws (**BELOW, RIGHT**).

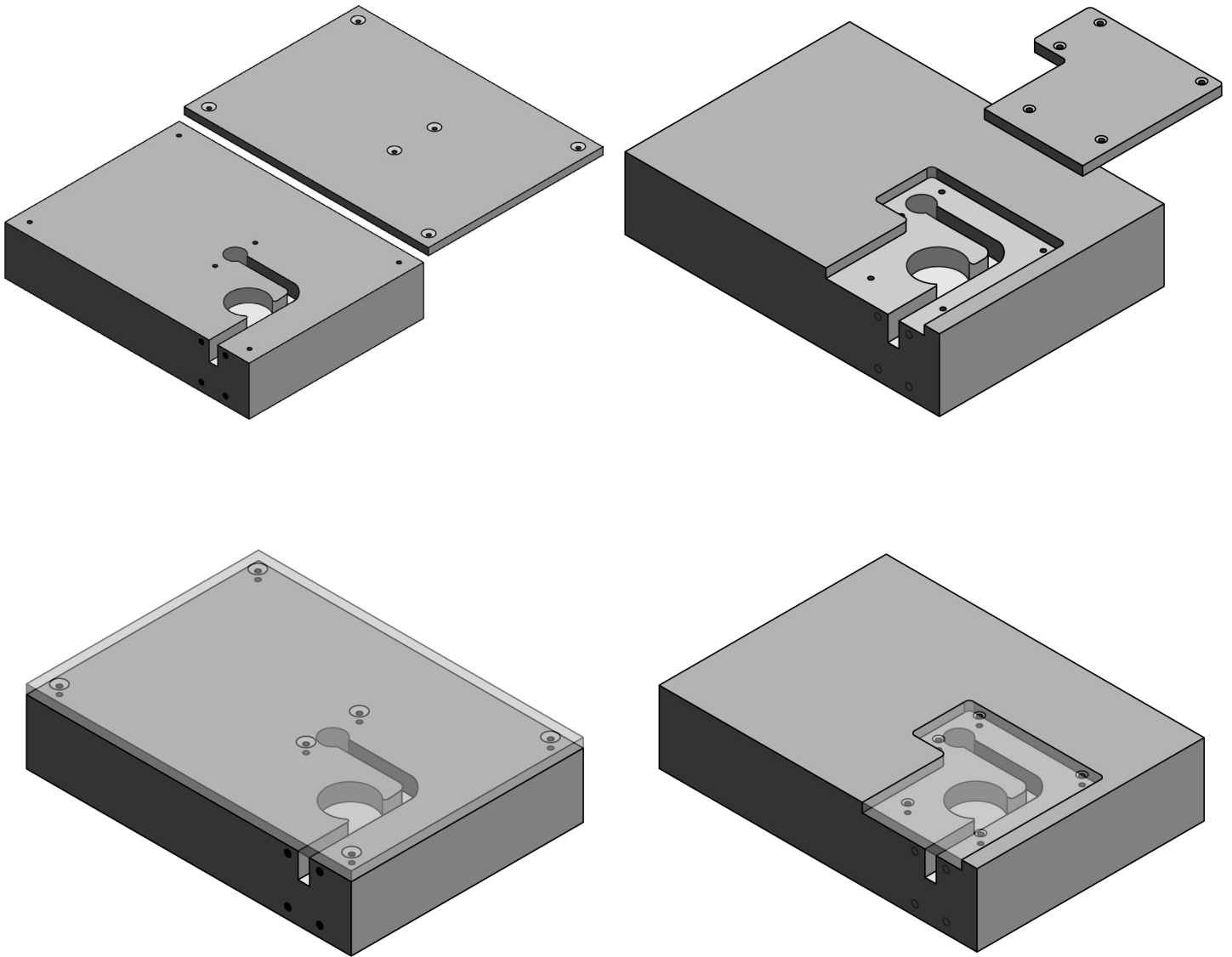

INSTALLATION SPECIFICATIONS *(continued)*

COVER PLATE—CLAMP PLATE INSTALLATIONS

The minimum cover plate thickness (**1 AT RIGHT**), regardless of sensor retaining plate method, corresponds to the sensor force range model, as shown in the table below.

COVER PLATE THICKNESS MIN

Pin Ø	Plate Thickness MIN	Fastener
3/32–7/64" (2.5–3.0 mm)	0.2" (5,0 mm)	8-36 (M4)
9/64–5/8" (4.0–23.0 mm)	0.25" (6,0 mm)	10-32 (M5)

Countersink screw heads and install (**2 AT RIGHT**) in the cover plate on each side of the sensor diameter to avoid any bending of the cover; incorporate and install other screws as necessary to secure cover. RJG recommends the use of 8-36 or 10-32 (M4 or M5).

NOTES *Countersink screw heads for cover plate fasteners to prevent head protrusion from plate.*

Clamp plate cover design is determined by customer. Contact RJG customer support (see page 55 for contact information) for questions.

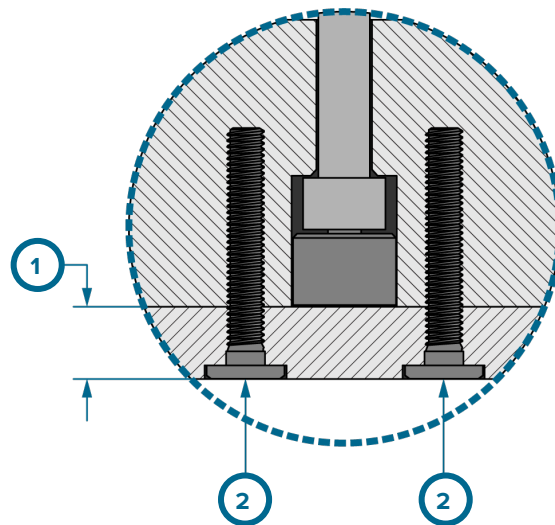

1 Cover Plate Thickness, MIN (refer to table)

2 Cover Plate Screws 8-36 or 10-32 (M4 or M5)

EJECTOR PLATE INSTALLATION

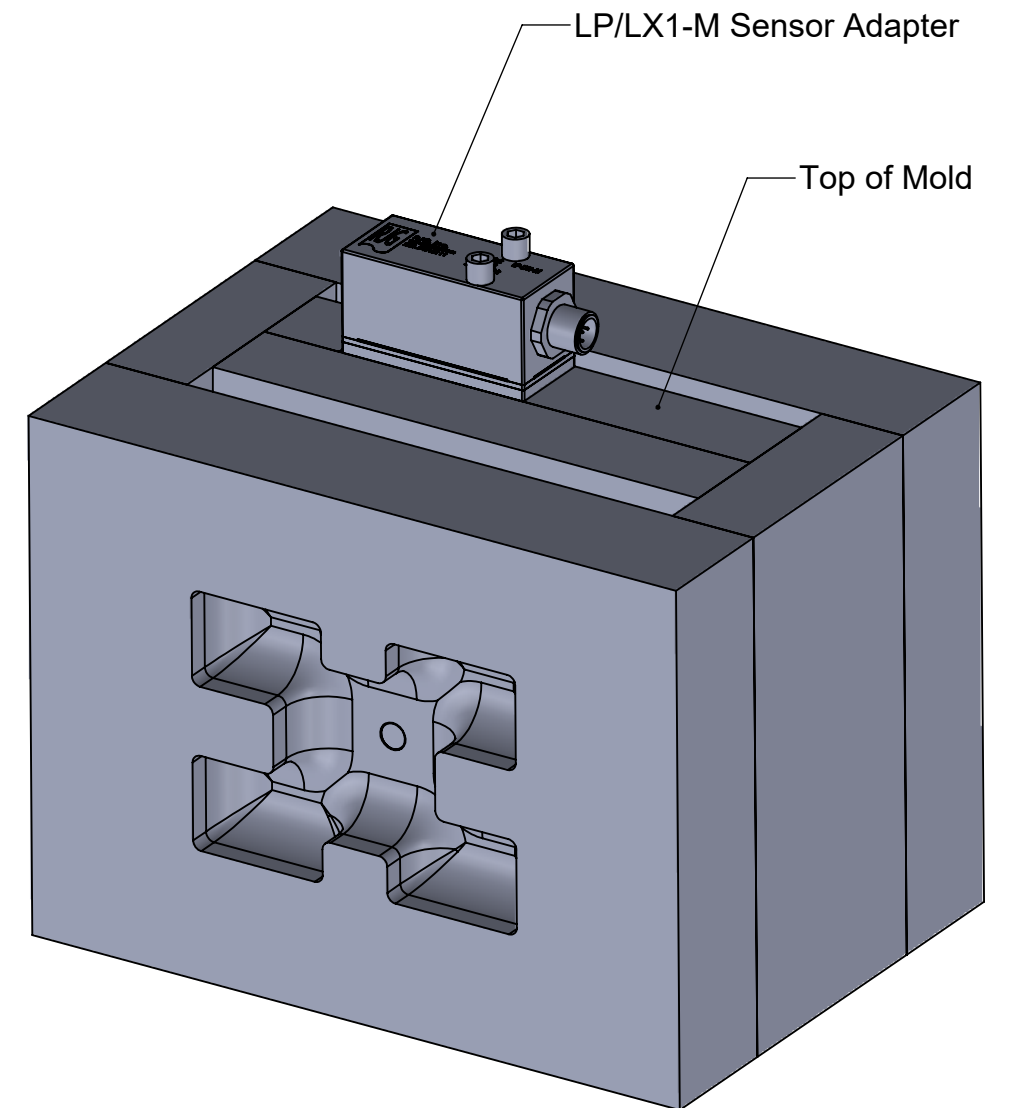
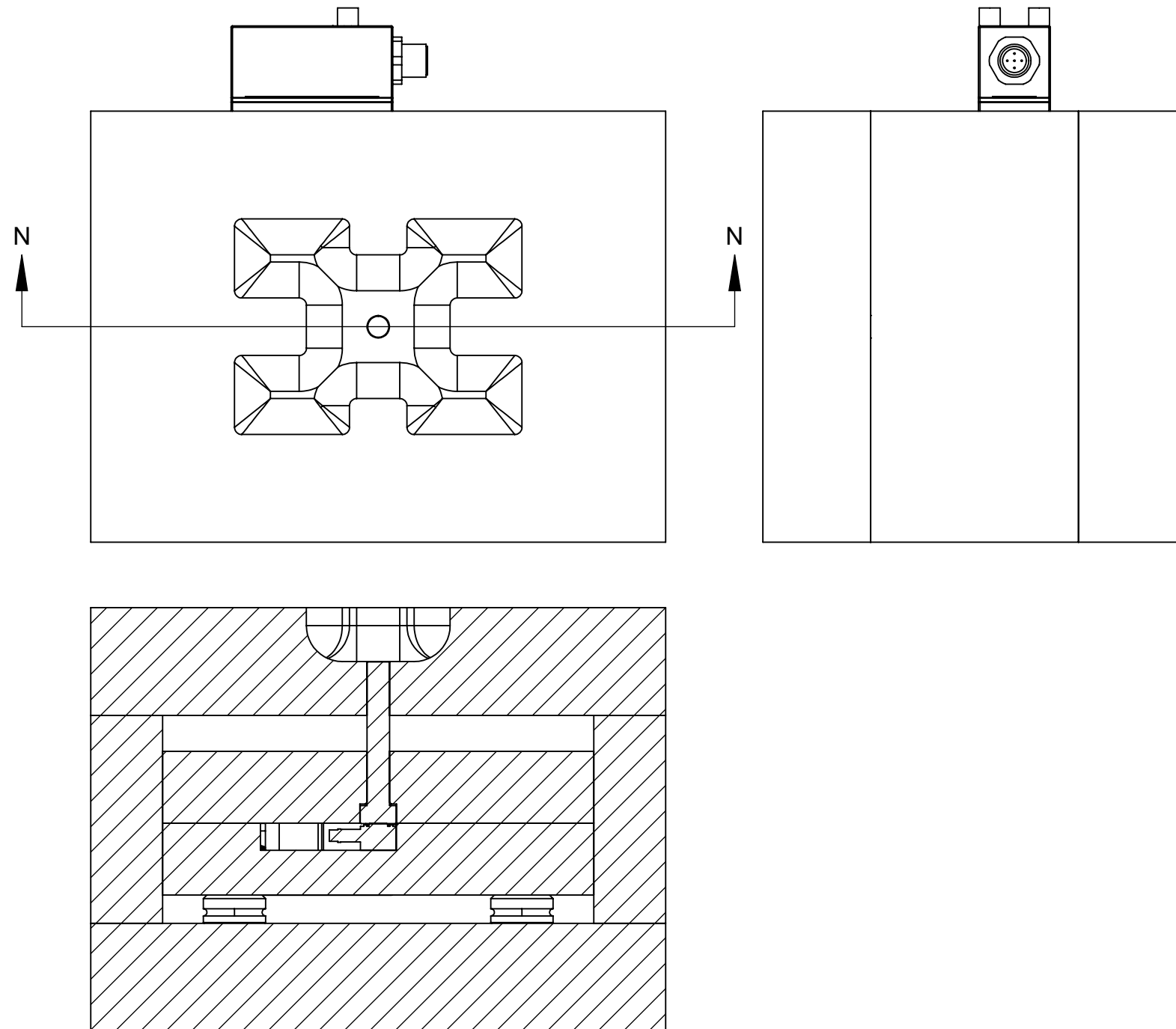

EJECTOR PLATE INSTALLATION

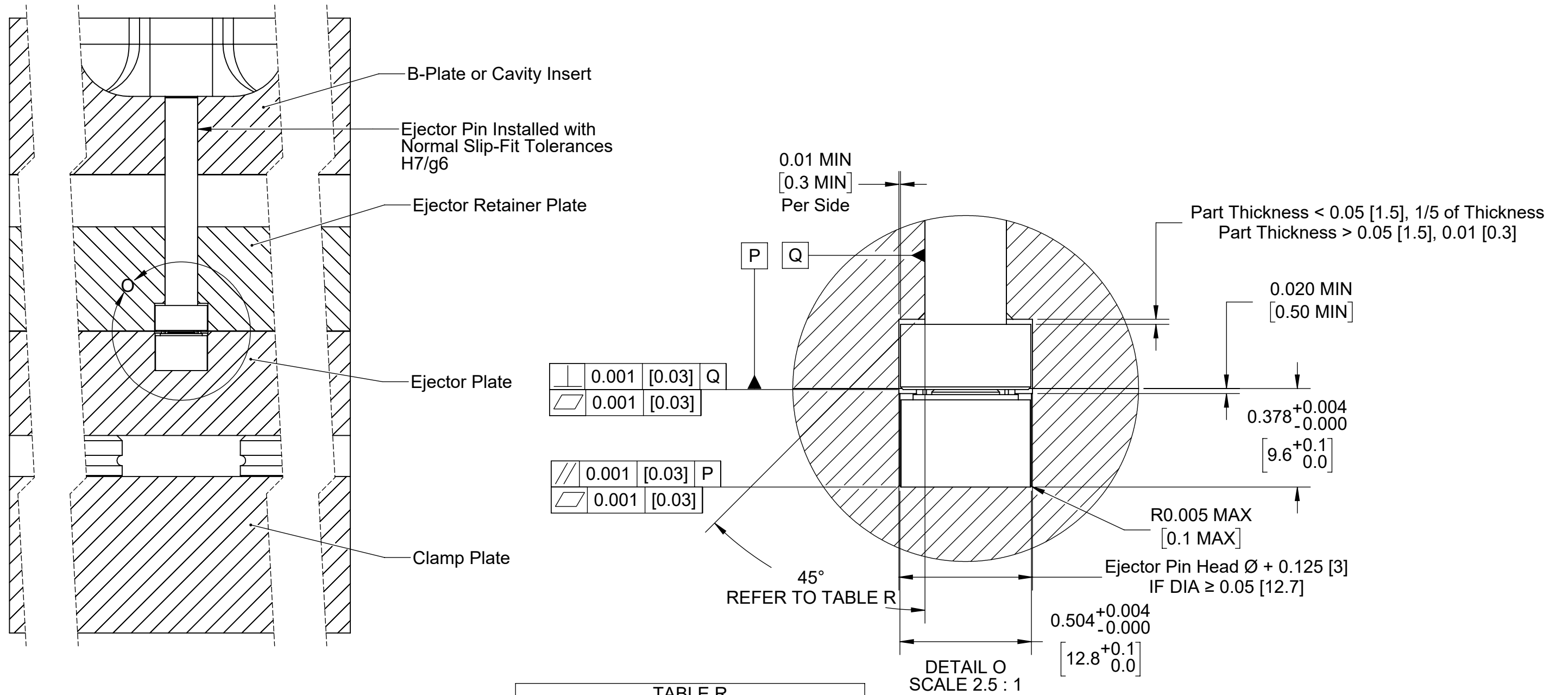

TABLE R	
Ejector Pin Ø	Chamfer Length
0.04–0.08 [1.0–2.0]	0.01 [0.3]
0.10–0.20 [2.5–5.0]	0.02 [0.4]
0.24–0.40 [6.0–10.0]	0.025 [0.6]

INSTALLATION SPECIFICATIONS (continued)

EJECTOR PLATE INSTALLATION

1. Sensor Pocket Machining

Sensor pockets are machined into the ejector plate. The pockets must be centered under the selected ejector pin measuring 0.504" +0.004/-0.0 (12,8 mm +0,1/-0,0 [1 at right]) DIA, and 0.378" +0.004/-0.0 (9,6 mm +0,1/-0,0 [2 at right]) deep.

- Use a 5/16" "dead sharp" end mill to achieve correct radius—sensor pocket corner radius MAX R 0.005" (0,10 mm [3 at right]).

If the ejector pin head DIA is greater than 0.50" (12,7 mm), machine a counterbore into the ejector plate equal to the ejector pin DIA plus 0.125" (3 mm) MIN by 0.02" (0,5 mm) MIN deep to allow the head of the ejector pin to clear the plate and rest only on the sensor when under pressure (4 & 5 at right).

2. Ejector Pin Pocket

Choose an ejector pin appropriate for the application (refer to "Sensor and Ejector Pin Size" on page 2). Machine a pocket for the ejector pin head in the ejector retainer plate that is equal to the ejector pin head DIA plus 0.01" (0,3 mm [6 at right]) MIN per side by ejector pin height plus 0.01" (0,3 mm [7 I at right]) MIN to eliminate potential preload on the sensor when installed.

- ⓘ NOTES** Ejector pin head clearance not to exceed 20% (1/5th) of part thickness at point of pin/part convergence.

Hole basis for ejector pins is ISO standard clearance fit H7g6—H7g6 is a sliding fit suitable for precision location fits.

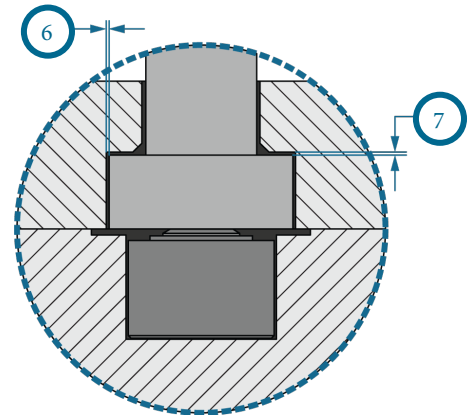
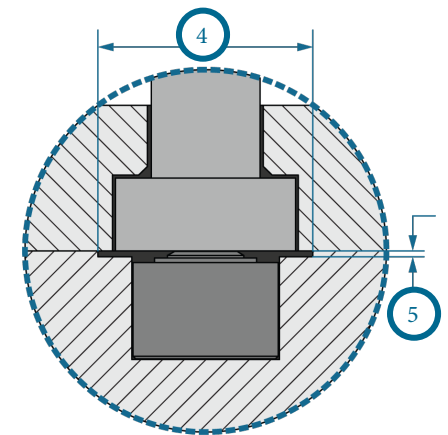
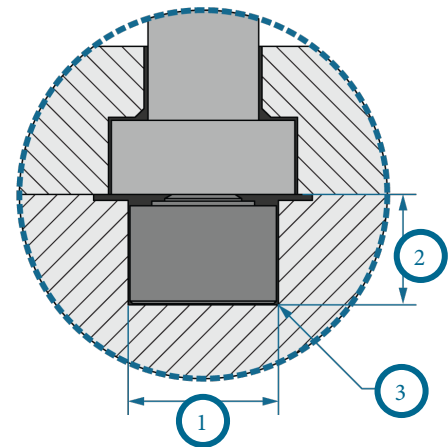

1 \varnothing 0.504" +0.004/-0.0 (12,8 mm +0,1/-0,0)	5 0.02" (0,5 mm) MIN
2 0.378" +0.004/-0.0 (9,6 mm +0,1/-0,0)	6 0.01" (0,3 mm) MIN per side
3 0.005" (0,10 mm) MAX R.	7 20% part thickness if \leq 0.05" (1,5 mm), 0.01" (0,3 mm) if part thickness $>$ 0.05" (1,5 mm) I
4 Pin Head DIA + 0.125" (3 mm), IF DIA \geq 0.50" (12,7 mm)	

INSTALLATION SPECIFICATIONS (continued)
SENSOR STEM AND CABLE CHANNELS

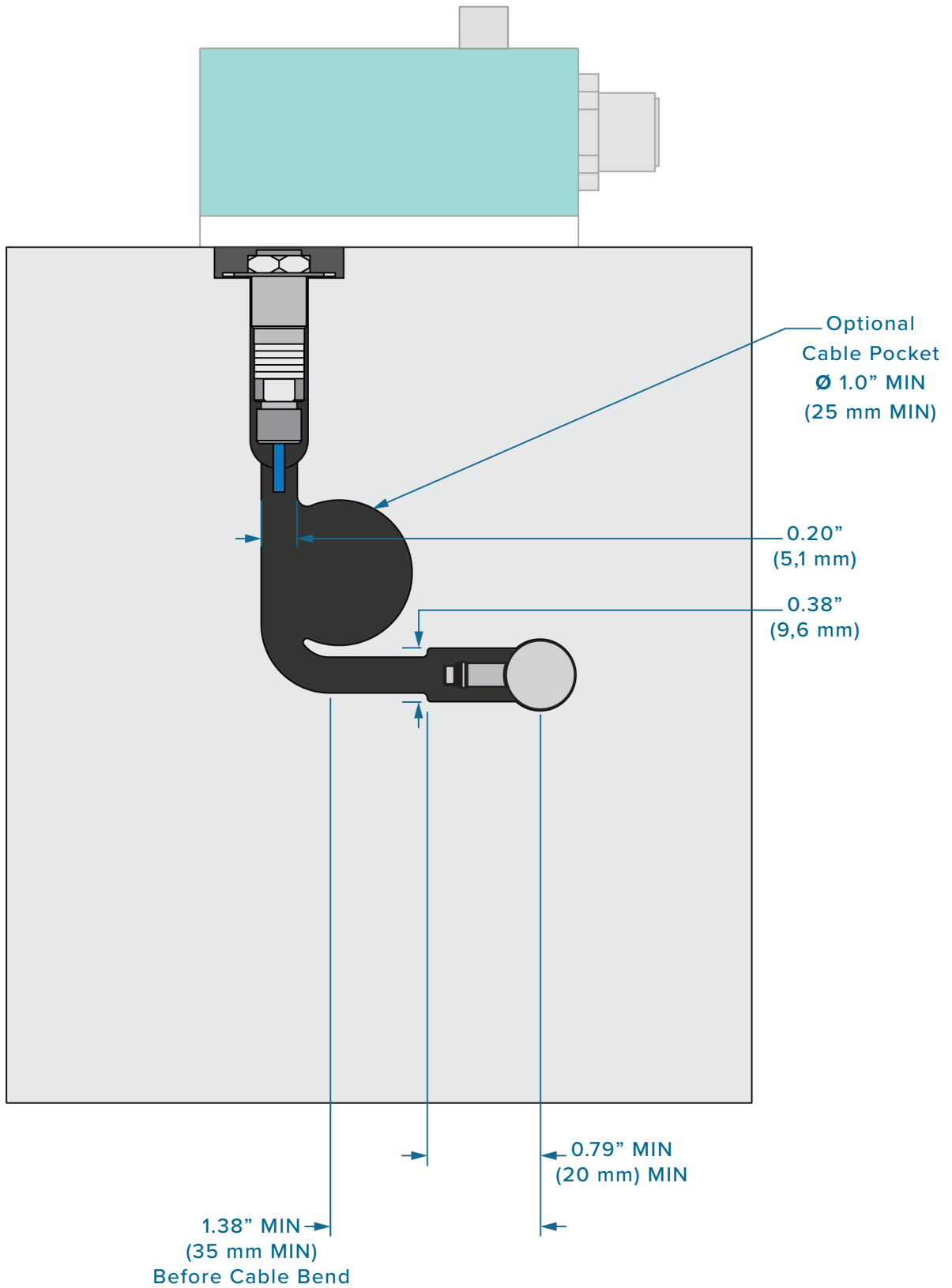

INSTALLATION SPECIFICATIONS (continued)

SENSOR STEM AND CABLE CHANNELS

1. Sensor Stem

- Machine a pocket for the sensor stem for 0.79" (20 mm [1 at right]) MIN in length by 0.38" (9,6 mm [2 at right]) wide, the same depth as the sensor.

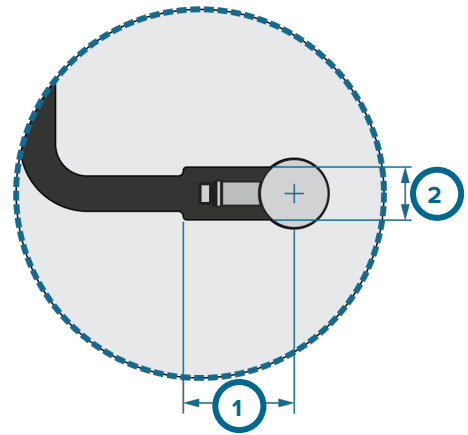

2. Sensor Cable Channel

- Machine a cable channel width and depth of 0.20" (5,1 mm [3 at right]) after the sensor stem.

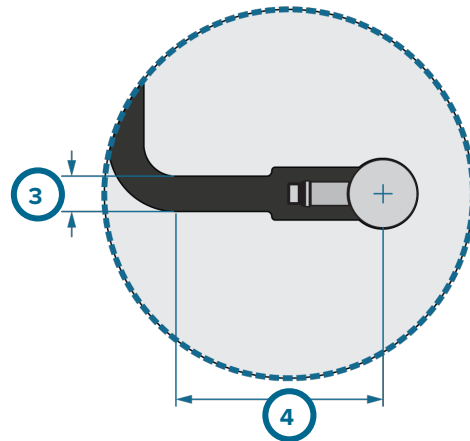

3. Sensor Cable Bend

- The sensor cable must not be bent within 1.38" (35 mm [4 at right]) MIN of sensor head center.

4. Excess Cable Pocket

- If necessary, a cable pocket may be machined to store excess cable. This requires a pocket of 1.0" (25,4 mm [5 at right]) DIA MIN for the cable to coil.

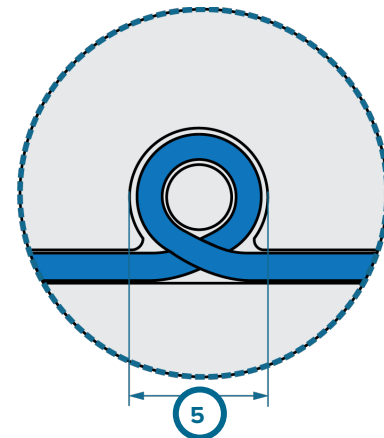

1	0.79" (20 mm) MIN
2	0.38" (9,6 mm)
3	0.20" (5,1 mm)
4	1.38" (35,0 mm) MIN from center of sensor head
5	∅ 1.0" (25,4 mm) MIN

INSTALLATION SPECIFICATIONS *(continued)*

SENSOR CABLE RETENTION

Sensor cable retention strategies must be considered during the mold design phase. Cables are often not the exact size needed, or do not easily remain in the cable channels during assembly and must be retained using one or more of the following methods.

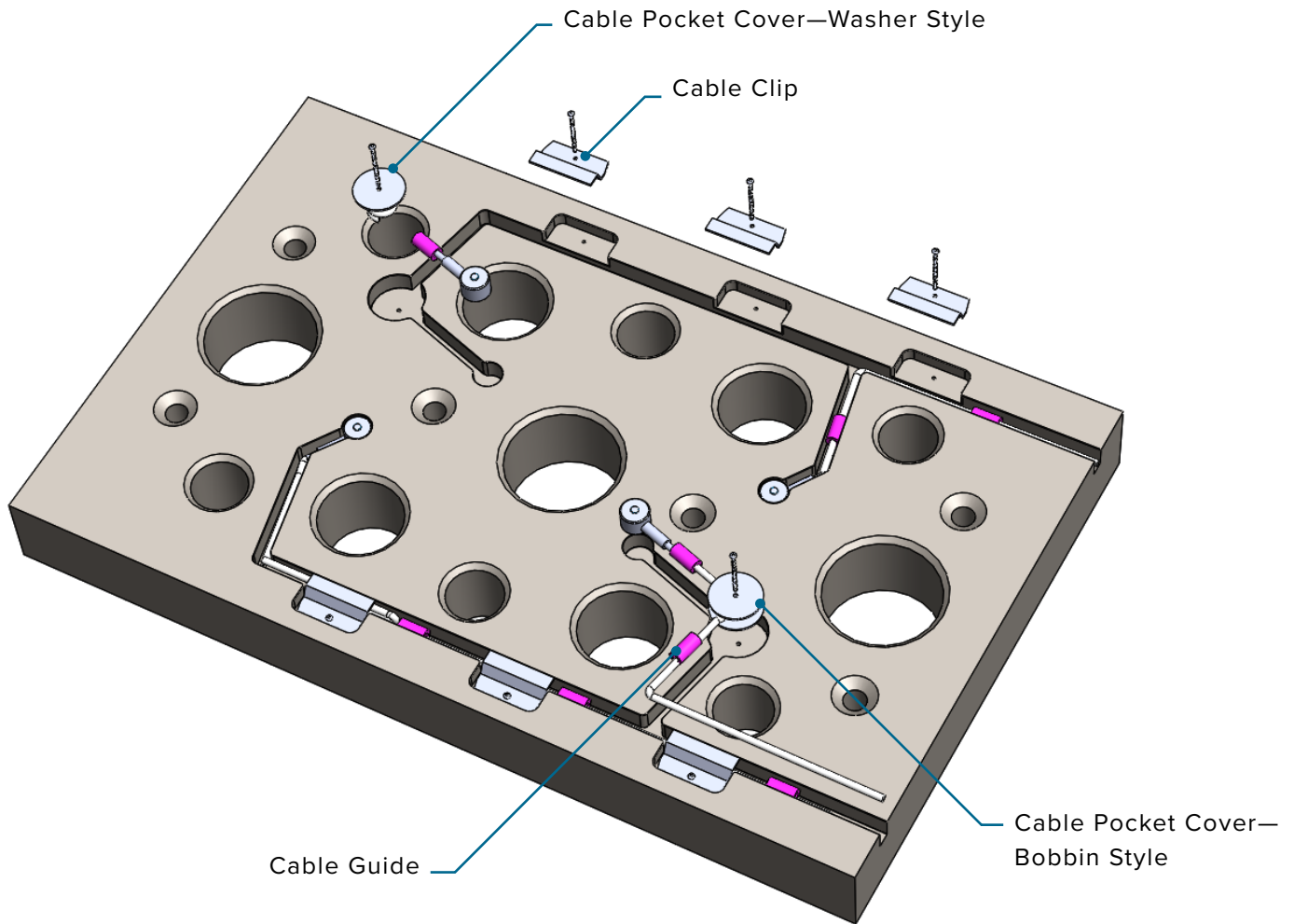

INSTALLATION SPECIFICATIONS *(continued)*

1. Cable Guides

Use self-locking cable guides (**1 AT RIGHT**) in cable channels to retain the sensor cable. Cable guides are silicone rubber tubes with a slot in them to accommodate the sensor cable; the cable guides fit snugly within the cable channel dimensions provided.

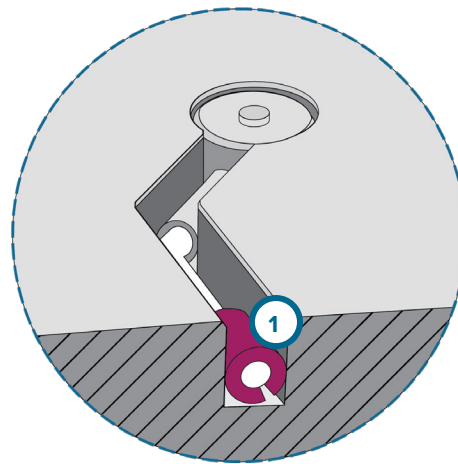

2. Cable Pocket Covers

If excess cable pockets are present, it may be useful to provide a cover (**2 AT RIGHT**) for the cable pocket with which to retain extra cable. Though RJG does not currently provide a solution specifically for this application, plastic or metal discs with a centrally-located hole, retained by a single bolt through the center, can be used to easily retain cable within the pocket. Alternatively, a bobbin-style device can be used similarly to retain cable within a pocket.

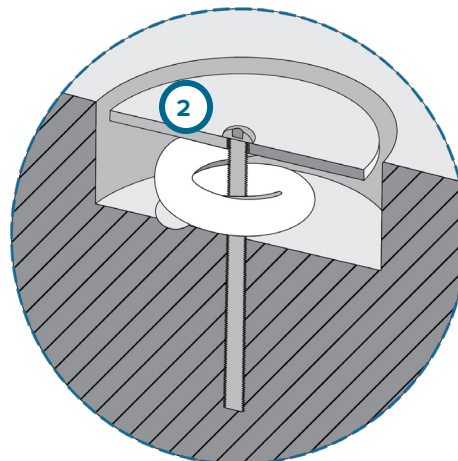

3. Cable Clips

Cables may also be retained in channels using cable clips (**3 AT RIGHT**); RJG does not currently provide this solution. Clips can be formed from sheet or plate metal and retained by machine screws. The clips can supplement or replace the use of silicone rubber cable guides, enabling an easier assembly of the tool.

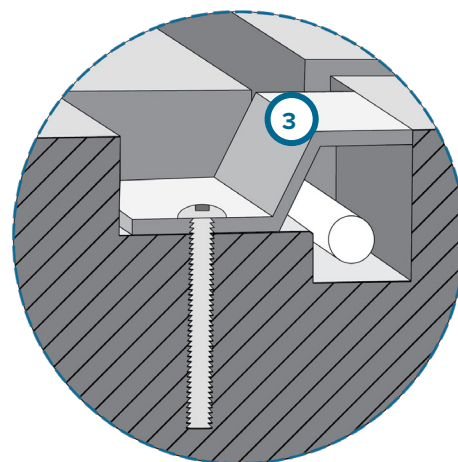

4. Cable Retention Putty

- Use cable retention putty to retain sensors where self-locking cable guides will not be effective, such as multiple sensor cable channels.

NON-STANDARD INSTALLATIONS

STATIC (NON-MOVING) EJECTOR PINS

While cavity pressure sensor installation with moving, or “working” ejector pins is recommended, in some situations a non-moving or “static” pin must be utilized. In most cases, static pins are installed directly into the cavity plate, or into a cavity insert. In some cases, static pins will extend through multiple plates, such as applications that extend back to the clamp plate. Read and follow all instructions, and refer to the provided figures to properly install sensors with static ejector pins.

1. Static Ejector Pins Overview

Static ejector pins are non-moving pins which sit on top of button-style sensors to transfer plastic pressure in the cavity to the sensor in a mold plate. Unlike moving ejector pins which self-clean during each ejection cycle, static pins can allow build-up of material around the pin over time. Static pins should have an O-ring on the end of the pin to prevent contamination build-up that contributes to measurement errors, allowing the sensors to read accurately over time.

Successful static pin installation provides lower sensor and installation costs; easier sensor maintenance; flexibility in sensor and pin sizing; and freedom in sensor location.

2. Ejector Pin Bore and Lead-In

Provide space in the sensor pocket for the sensor and static pin allowing for clearance above the pin head equal to 1/5th of the part thickness at pin location (1 **AT RIGHT**) if part thickness is less than or equal to 0.06” (1,5 mm), or 0.012” (0,3 mm (1 **AT RIGHT**)) if the part thickness at pin location is greater than 0.06” (1,5 mm).

From the sensor and pin head pocket, provide a clearance of the pin diameter plus 0.06” (1,5 mm (2 **AT RIGHT**)).

Step down the bore to a standard ejector pin bore of H7/g6 (3 **ABOVE**) (in which the ejector pin is able to freely move) before the cavity to provide a sealing surface

STATIC PIN INSTALLATION

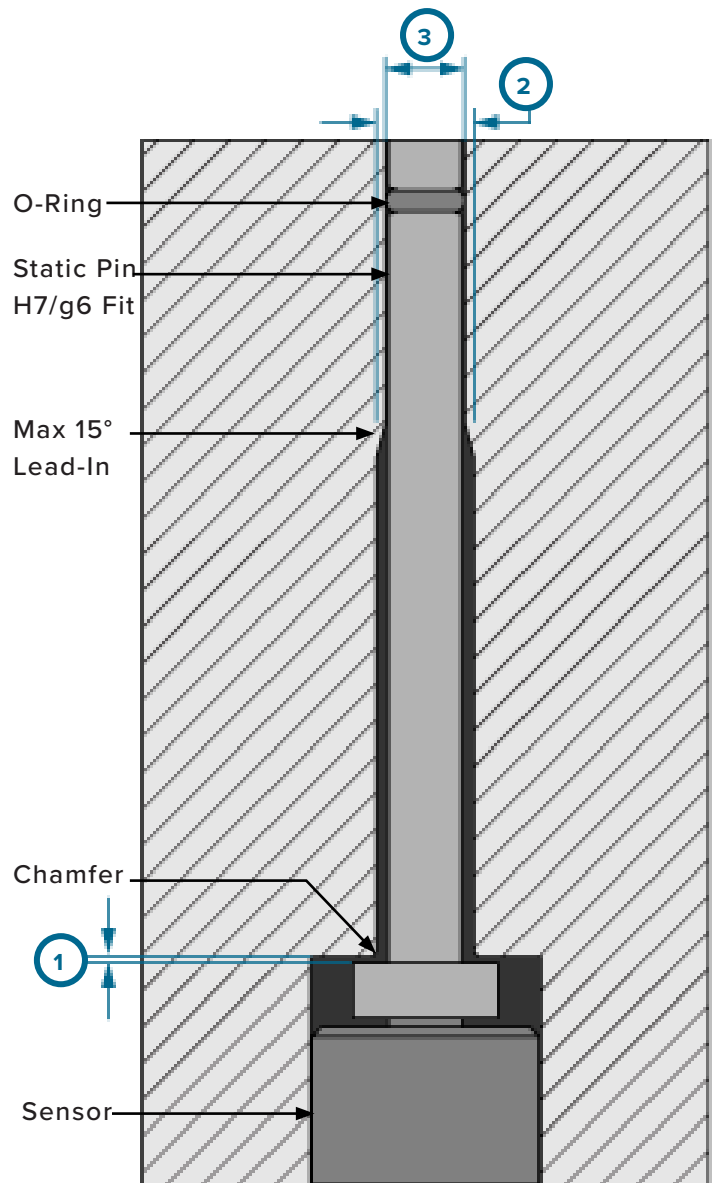

CAUTION These guidelines are for pins 3/32” (2,5 mm) diameter or larger. Please contact RJG Customer Support for installation of static pins smaller than 3/32” (2,5 mm) in diameter

for the O-ring at the end of the static pin. Chamfer the transition between the sensor and pin head pocket and the pin bore, and also the transition between the pin bore and standard fitment at the end of the pin (no more than 30°/15° per side).

NON-STANDARD INSTALLATIONS (continued)

3. O-ring Sizing

O-ring sizes are designated by inside diameter (ID [**1 AT RIGHT**]) and cross section (CS [**2 AT RIGHT**]), usually in inches. A 0.072 X 0.036 O-ring would have an ID of 0.072" and a CS of 0.036".

The O-ring is installed in the ejector pin's groove. The groove is measured by diameter (**3 AT RIGHT**) and width (**4 AT RIGHT**). The diameter is cut to ensure O-ring stretch of 0–10%. The depth is cut to ensure O-ring compression of 20–35%. Ensure the pin end before O-Ring groove is 0.030" (0,76 mm [**5 AT RIGHT**]) **MIN FOR STEELSAFE**. Contact RJG® for assistance in sizing and tolerancing O-rings and installation requirements. Refer to the table below for RJG recommended, in-stock O-rings.

4. O-Ring Installation

Improper O-ring installation can cause tears if it is pulled over the sharp ejector pin edge. Use an installation tool constructed of the same diameter as the ejector pin, with a tapered end.

The end can be ground, usually by a grinding wheel, and buffed by a wire wheel to remove any burrs. Slide the O-ring onto the tapered end of the installation tool, and then slide onto the end of the static pin. (Refer to figures at right.)

5. Pin and O-Ring Bore Installation

Use an O-ring lubricant to help prevent damage when inserting the pin into the bore. Many silicone-based lubricants can damage silicone O-rings. RJG, Inc. recommends P-80 THIX lubricant from International Products Corporation (<http://www.ipcol.com/shopexd.asp?id=31>). Rotate the pin as it is being inserted to ease installation and limit potential O-ring damage.

STATIC (NON-MOVING) EJECTOR PINS

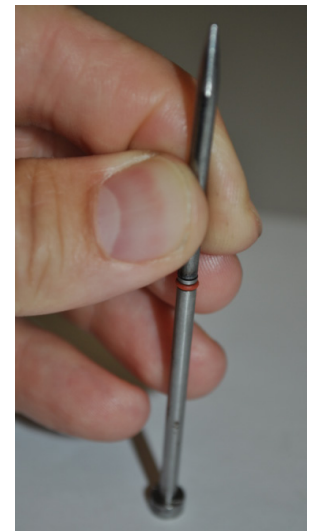
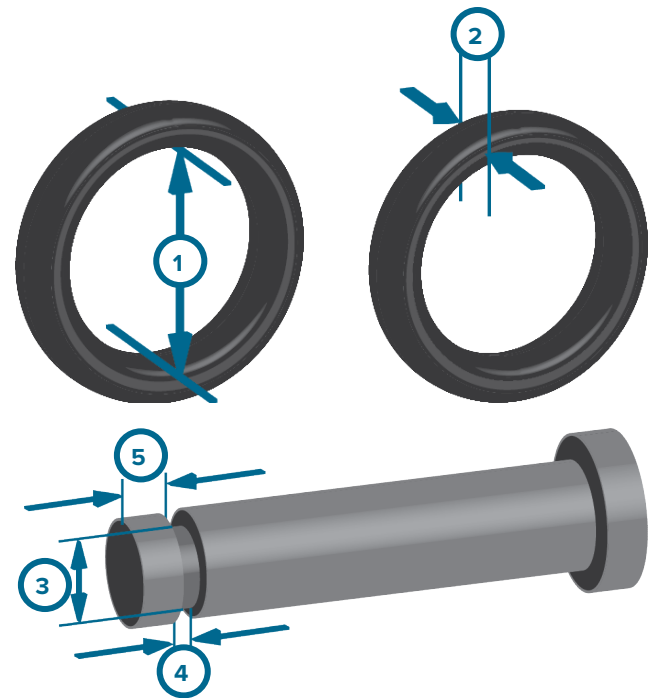

Nominal Material Pin Size	O-RING			Units	GROOVE SPEC.				BORE SPEC.	
	Material	Size (Metric)	RJG Part #		Width (4, above)	Width Tol (+/-)	Groove DIA (3, above)	DIA Tol (+/-)	Bore DIA	Bore Tol (+ Tol, -0)
4,0 mm	Silicone	2,7 x 0,65	85-6157-000	inches	0.038	0.003	0.1137	0.0019	0.1575	0.0005
2,5 mm		1,4 x 0,6	85-6159-000		0.032	0.003	0.0667	0.0010	0.0984	0.0005
4,0 mm		2,7 x 0,65	85-6157-000	mm	1,00	0,08	2,888	0,048	4,0	0,012
2,5 mm		1,4 x 0,6	85-6159-000		0,80	0,08	1,695	0,025	2,5	0,012

NON-STANDARD INSTALLATIONS (continued)

6. Sensor Readings

Data from the same mold is pictured below (typical results—not guaranteed).

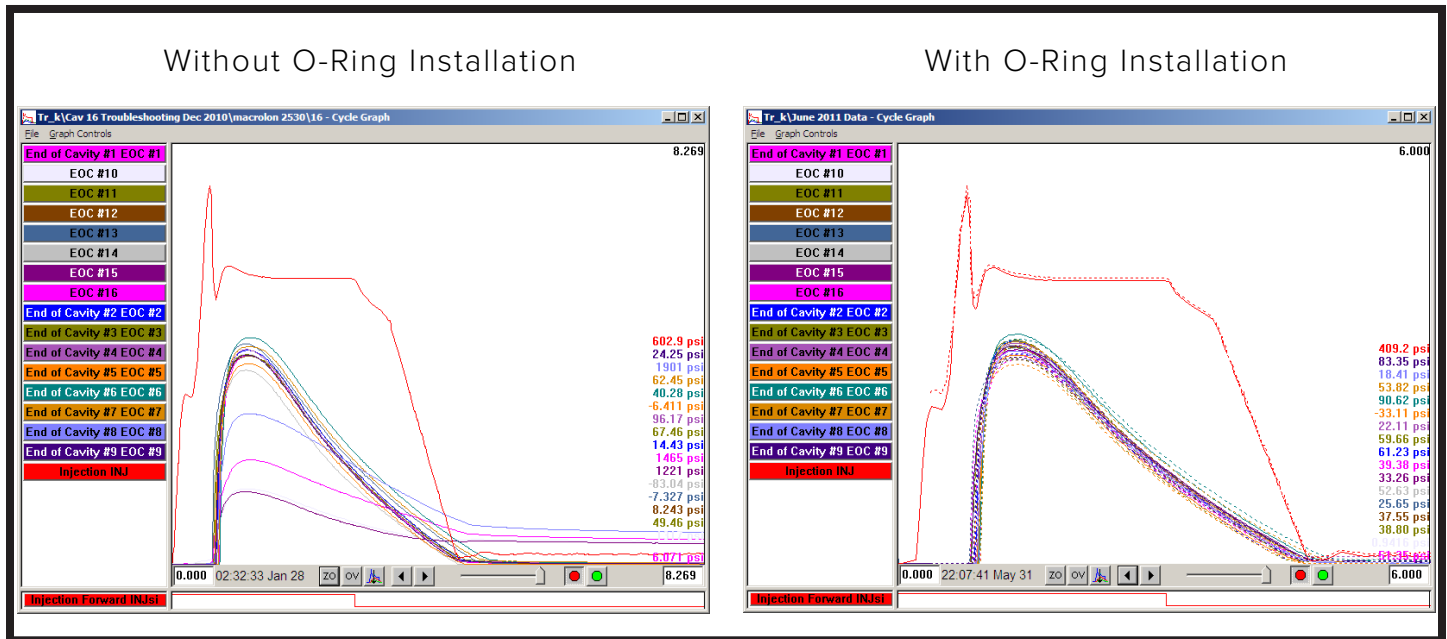

Above Left: Three sensors are reading too low due to contamination—without O-rings installed.

Above Right: The template and solid lines after four months of continuous production; the sensors continue to read consistently with O-rings installed.

Proper installation will provide a long service life of O-rings inside the mold. Only in the event of the following two instances will O-rings require replacement:

7. Flashing

If material flashes around the pin, it is necessary to pull the pin and remove the flashed material during regular preventative maintenance cycles. The O-ring must be replaced.

8. O-Ring Damage

When a pin is removed for inspection and/or cleaning during mold maintenance, inspect the O-ring for damage. Repeated installation and removal can cause nicks, cuts, or other damage to O-rings. Damaged O-rings must be replaced.

NON-STANDARD INSTALLATIONS (continued)

MULTIPLE EJECTOR PINS

Ejector pins are often grouped in small areas that do not allow for traditional cavity pressure sensor installation. Read and follow all instructions, and refer to the provided figures to properly install sensors with multiple ejector pins.

1. Multiple Ejector Pin and Sensor Placement

When multiple ejector pins are located too closely together to permit cavity pressure sensor placement under a single pin, a cover plate can be utilized to allow a selected pin to contact the sensor and prevent other pins from interfering.

The ejector pin retainer plate is modified to fit the cover plate so that it is recessed and flush with the ejector plate, and covers the area of the sensor body and unused ejector pins. The cover plate is mounted with four screws.

The cover plate mounting screws must be flush with the ejector plate and must not be in contact with the ejector pins, since constant pressure on the screws will cause them to fail.

2. Ejector Pin and Counter-Bore Clearance

Always use standard ejector pin clearances when installing cavity pressure sensors under ejector pins to prevent damage or destruction of the pins, sensors, and mold. Proper ejector pin head and counter-bore clearance will allow the static pin to move freely in the ejector pin bore.

PIN, SENSOR, & PLATE INSTALLATION

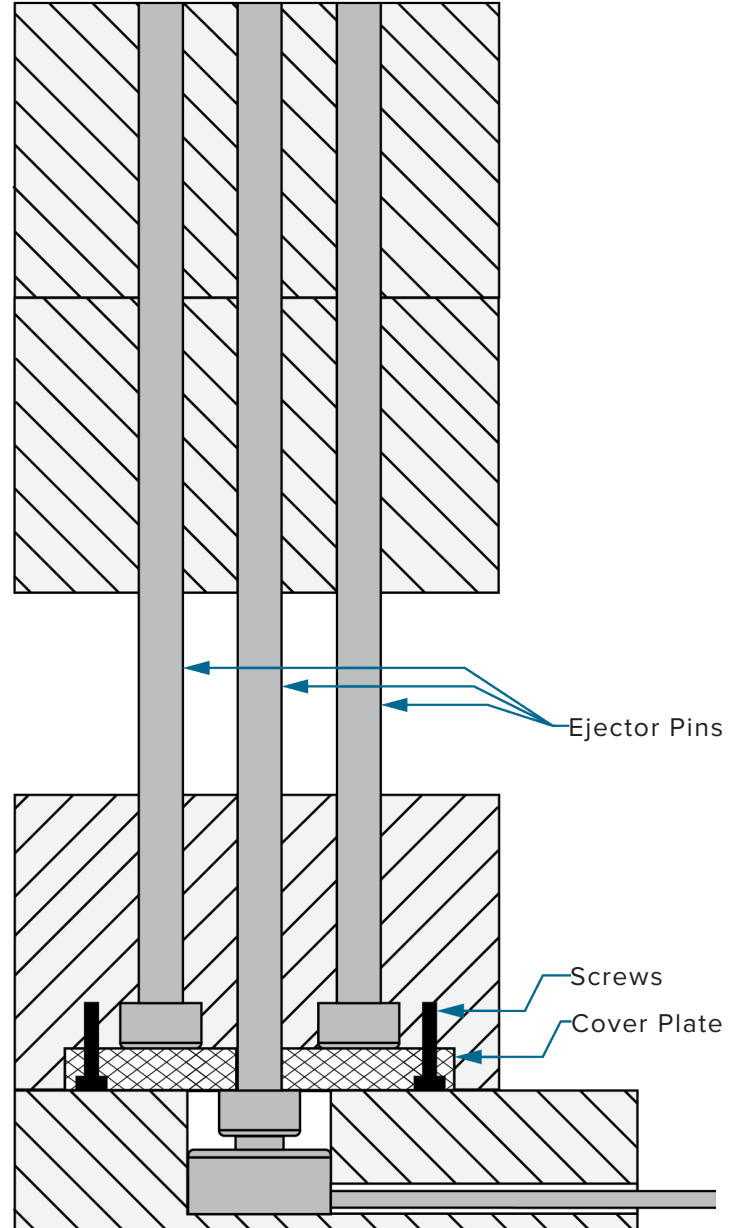

NON-STANDARD INSTALLATIONS (continued)

STATIC PIN EXAMPLE

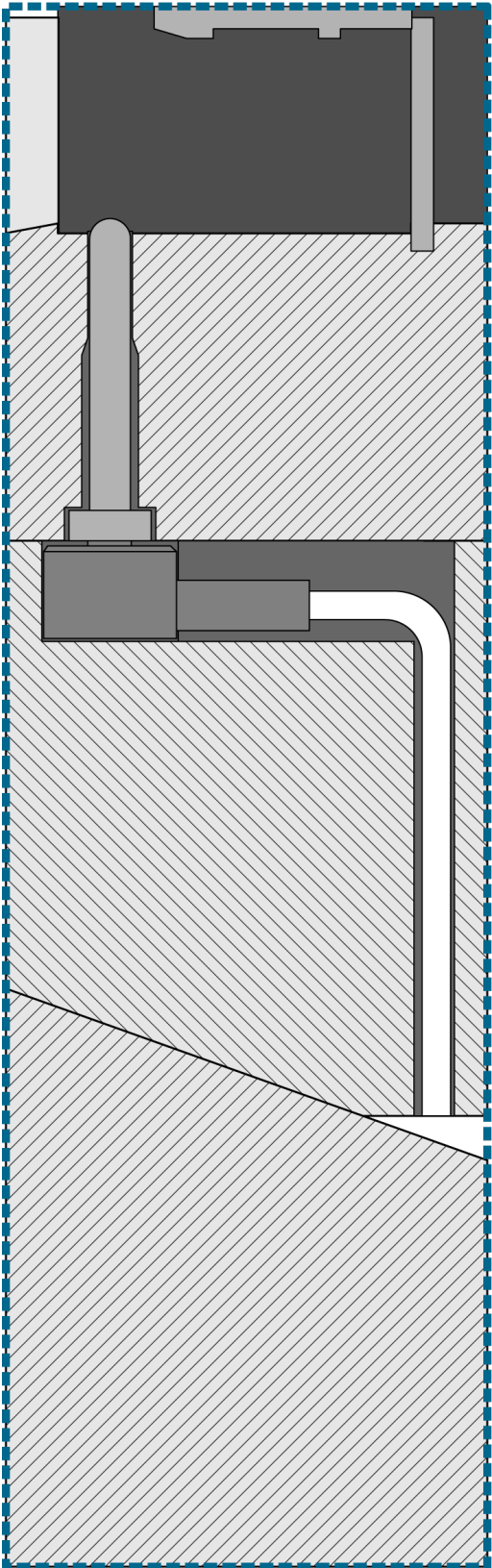

NON-STANDARD INSTALLATIONS (continued)

STATIC TRANSFER PIN EXAMPLES

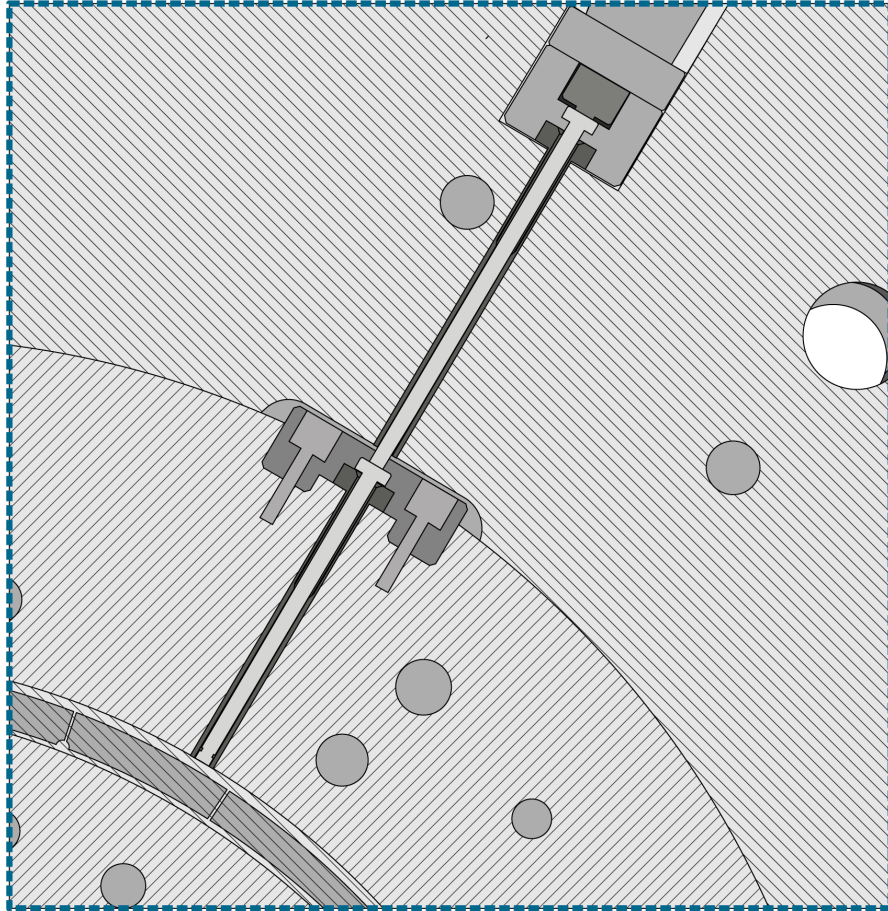
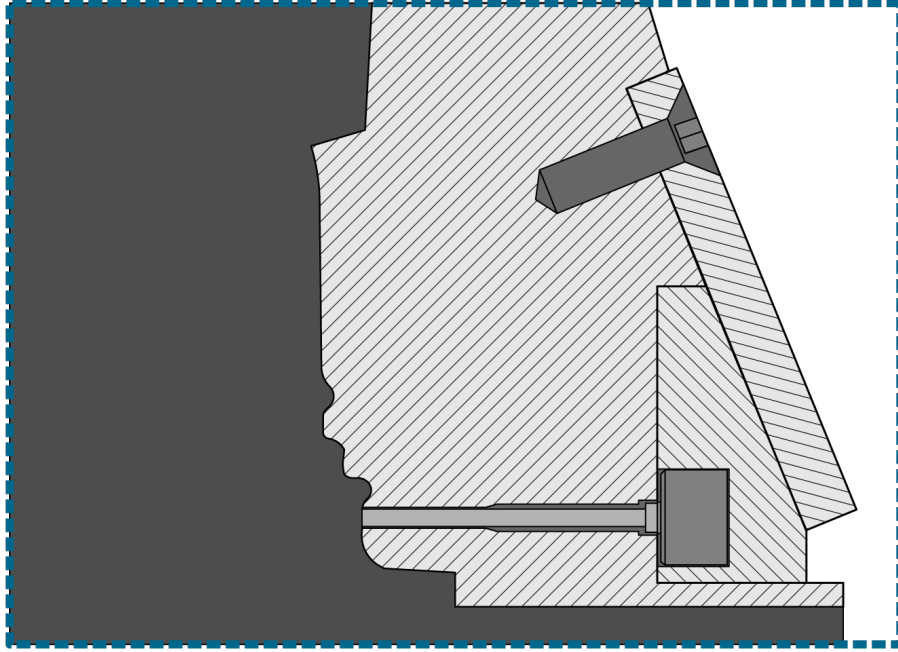

INSTALLATION VALIDATION

SENSOR INSTALLATION CHECK—CLAMP PLATE (TYPICAL) INSTALLATIONS

Verify that the each sensor, transfer pin, and ejector pin pocket is machined correctly.

PRE-ASSEMBLY CHECKS

1. Indentation Test (with sensor)

With the clamp plate disassembled, sensor in place, and cover plate removed, push the sensor and transfer pin forward; there should be 0.012–0.02" (0,3–0,5 mm) clearance between the sensor bottom and the clamp plate/sensor pocket bottom before the cover plate surface. Verify that the pin moves freely without any resistance.

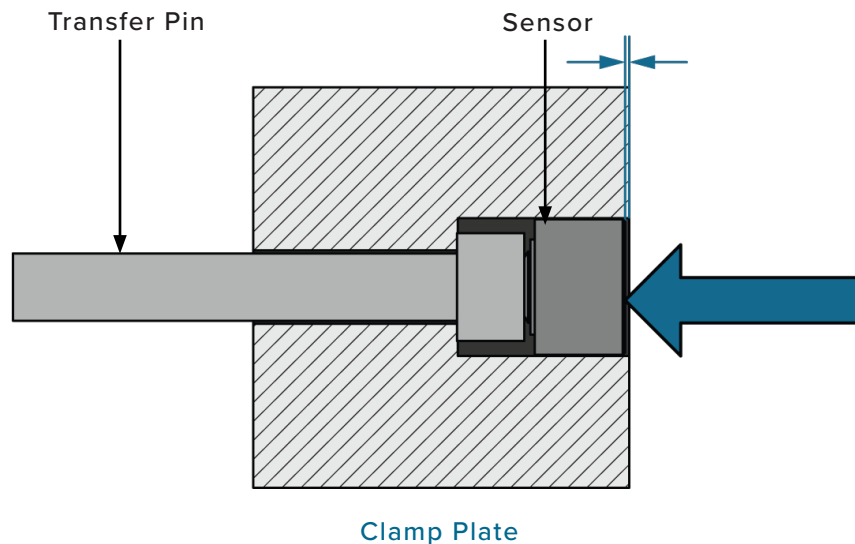

2. Flush Test (with sensor)

With the transfer pin, sensor, and cover plate installed, place the ejector plate above the clamp plate, and position fully back. Verify that the counterbore depth equals 0.012" (0,3 mm) and that the diameter is larger than the ejector pin head; the transfer pin should be flush with the ejector retainer plate.

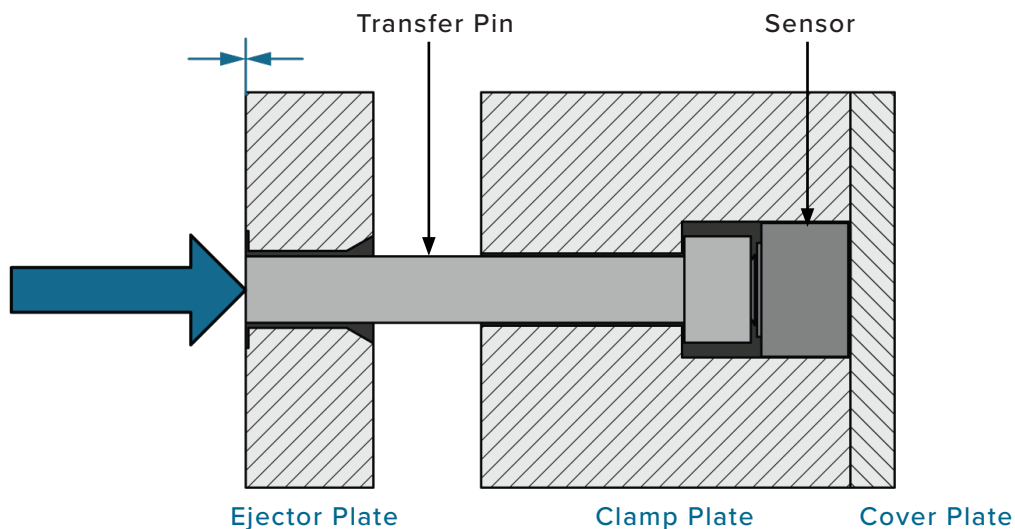

SENSOR INSTALLATION CHECK—CLAMP PLATE (TYPICAL) INSTALLATION *(continued)*

3. Indentation Test (with Ejector Pin)

With the ejector pin installed, push on the ejector pin; verify the clearance of 0.012” (0,3 mm (or 1/5 part thickness)) exists between the bottom of the ejector pin head and the ejector retainer plate surface.

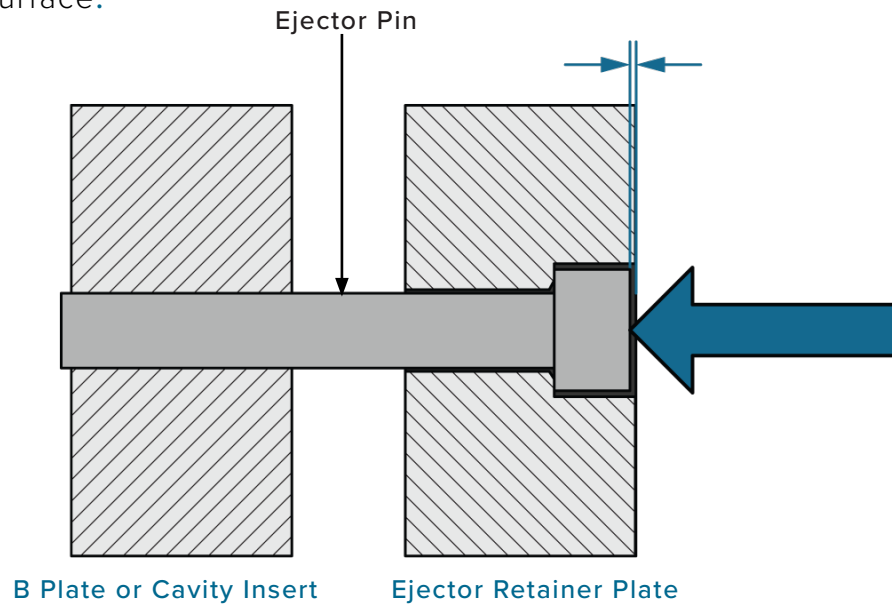

4. Flush Test (Full Stack)

With the sensor, ejector, and transfer pin installed, and the ejector plate in the injection position, fixed towards clamp plate, the ejector pin should be flush with the ejector plate/ cavity surface.

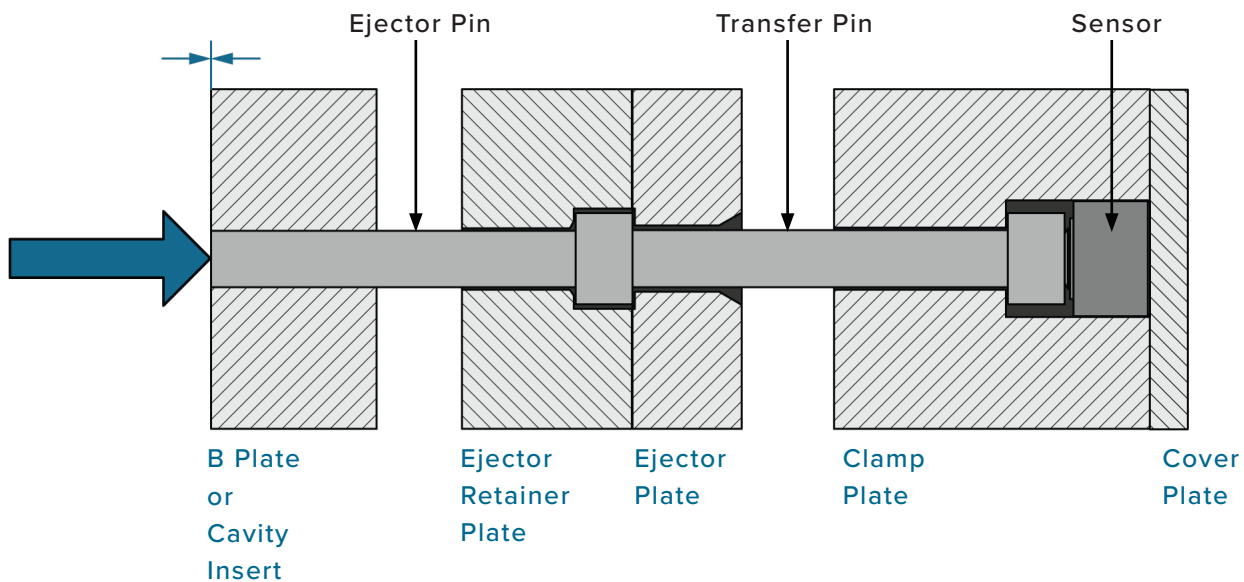

SENSOR INSTALLATION CHECK—CLAMP PLATE (TYPICAL) INSTALLATION *(continued)*

POST-ASSEMBLY CHECKS

1. Protrusion Test (without sensor)

With the ejector and transfer pins installed, the ejector plate in injection position, and the ejector plate fixed towards clamp plate, press the ejector and transfer pin together, towards the cavity; the ejector pin should protrude 0.008–0.01” (0,2–0,3 mm).

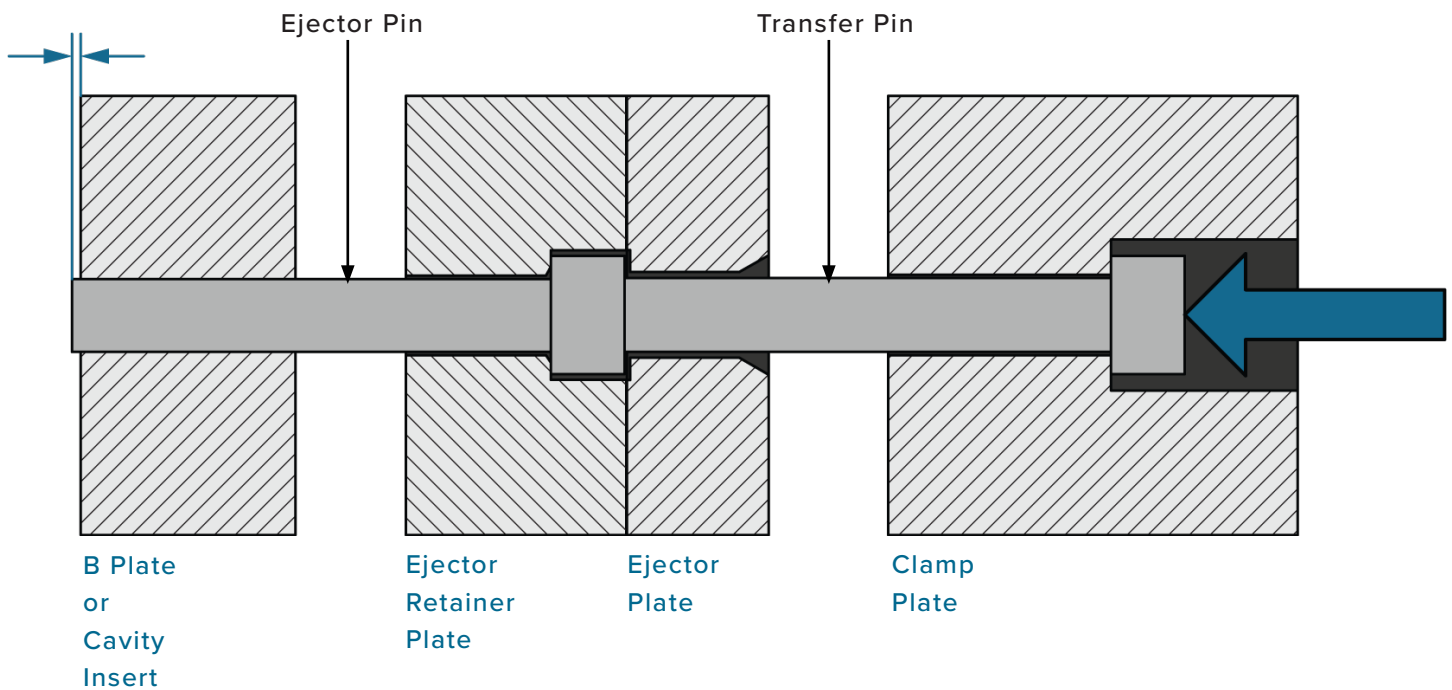

SENSOR INSTALLATION CHECK—CLAMP PLATE (TYPICAL) INSTALLATION *(continued)*

2. Indentation Test (without sensor)

With the ejector and transfer pins installed, the ejector plate in the injection position, and the ejector plate fixed towards clamp plate, press the ejector and transfer pin together, away from the cavity; the ejector pin should recess in the ejector plate 0.008–0.01" (0,2–0,3 mm).

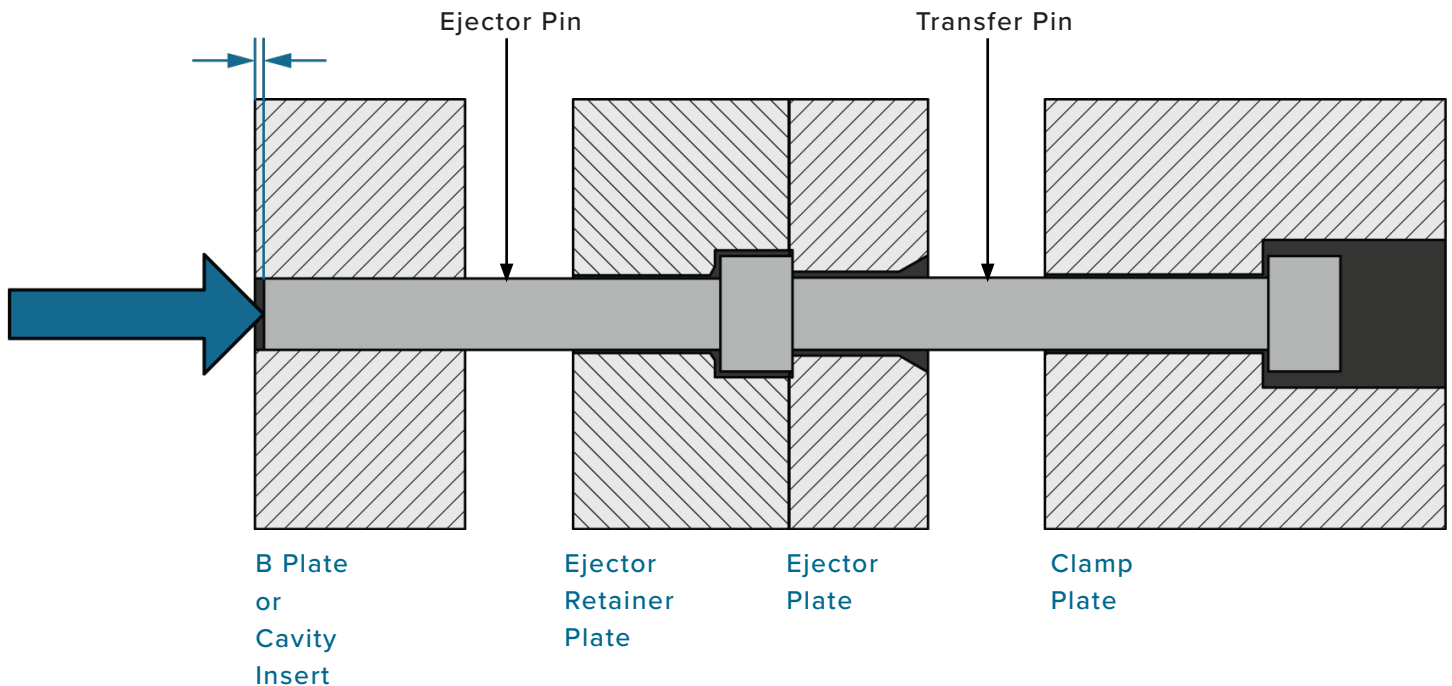

3. Flush Test (with sensor)

With the sensor, ejector, and transfer pin installed, and the ejector plate in the injection position, fixed towards clamp plate, the ejector pin should be flush with the ejector plate/cavity surface.

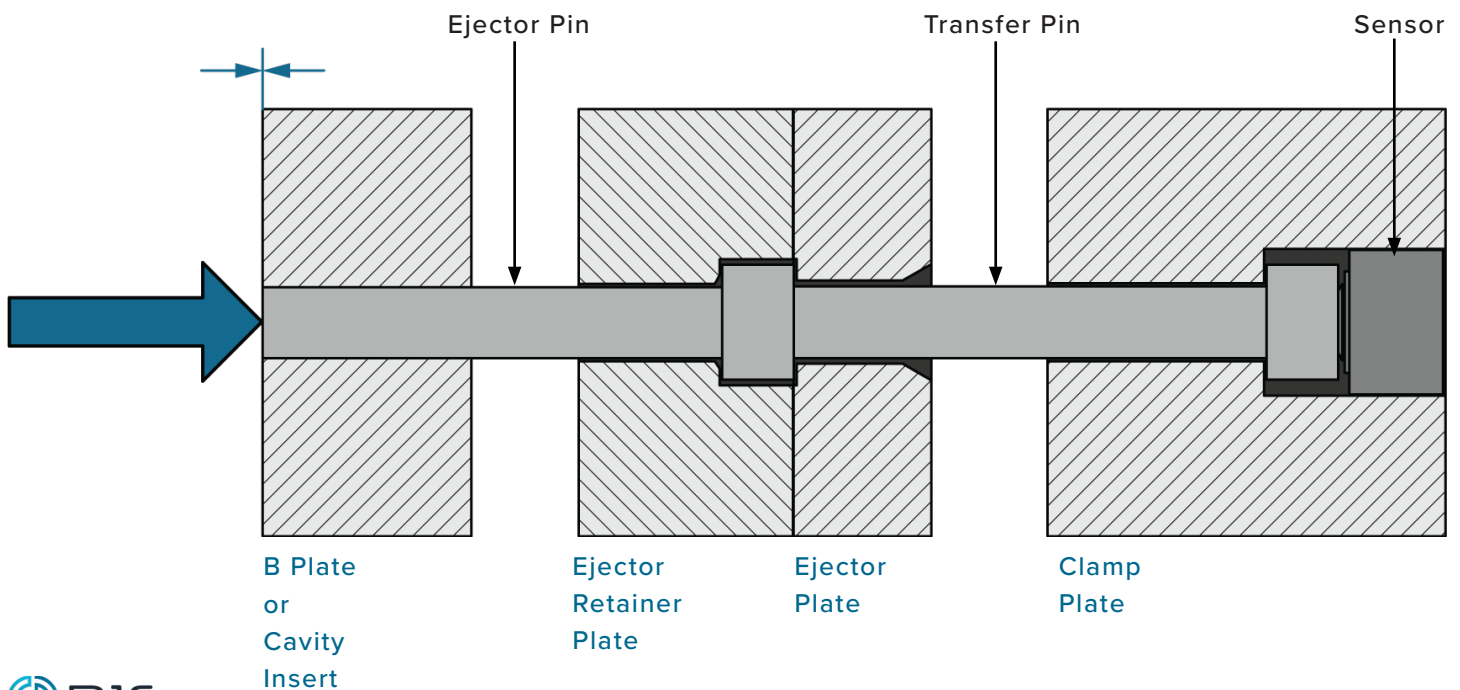

SENSOR INSTALLATION CHECK—CLAMP PLATE (HEAD-TO-HEAD) INSTALLATIONS

Verify that the each sensor, transfer pin, and ejector pin pocket is machined correctly.

PRE-ASSEMBLY CHECKS

1. Indentation Test (without sensor)

With only the transfer pin installed, push on the transfer pin head and verify a clearance of exists 0.012" (0,3 mm) MIN between the transfer pin head and retainer ejector plate surface.

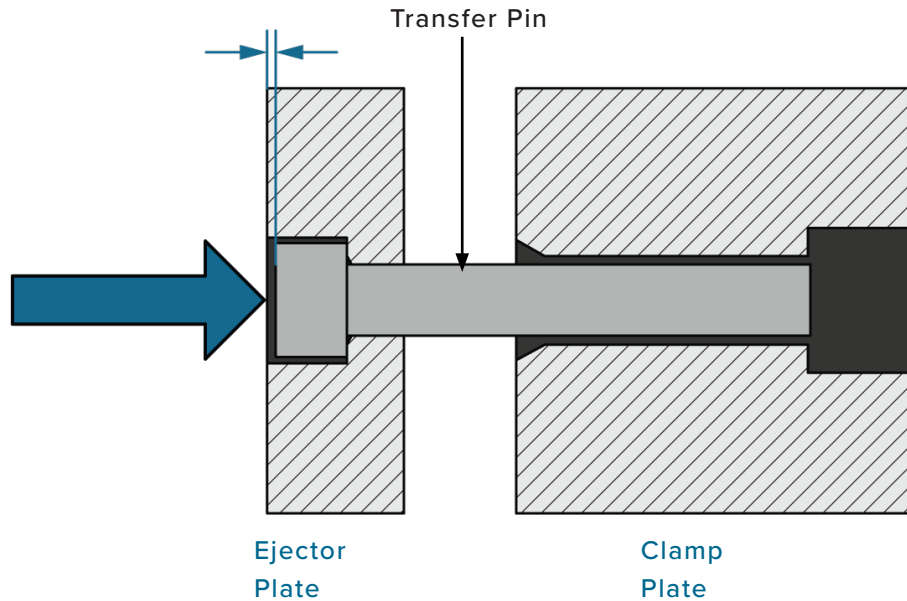

2. Indentation Test (with Ejector Pin)

With the ejector pin installed, push on the ejector pin; verify the clearance of 0.012" (0,3 mm (or 1/5 part thickness)) exists between the bottom of the ejector pin head and the ejector plate surface.

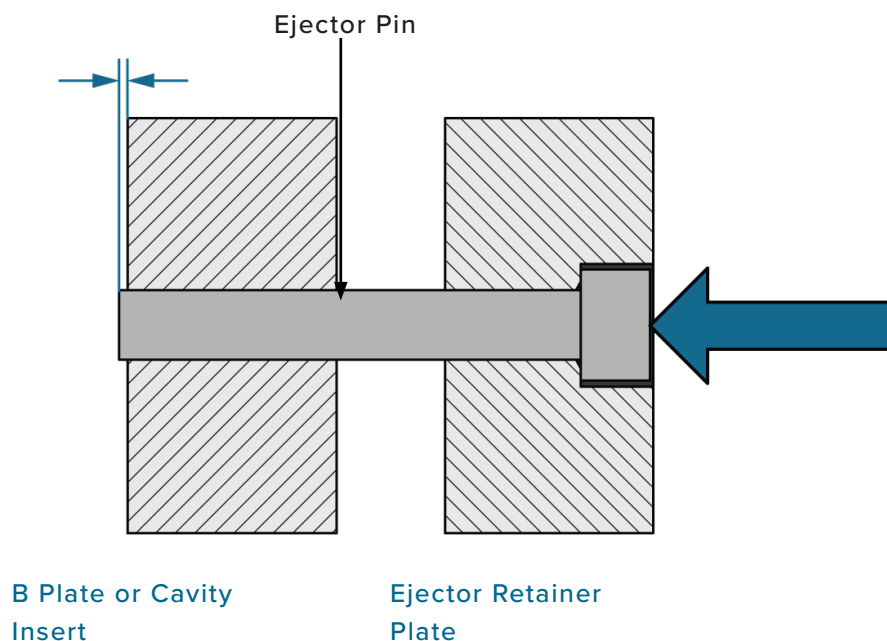

SENSOR INSTALLATION CHECK—CLAMP PLATE (HEAD-TO-HEAD) INSTALLATION (continued)

3. Indentation Test (with sensor)

With the clamp plate disassembled, sensor in place, and cover plate removed, push the sensor and transfer pin forward; there should be 0.012–0.02” (0,3–0,5 mm) clearance between the sensor bottom and the clamp plate/sensor pocket bottom before the cover plate surface. Verify that the pin moves freely without any resistance.

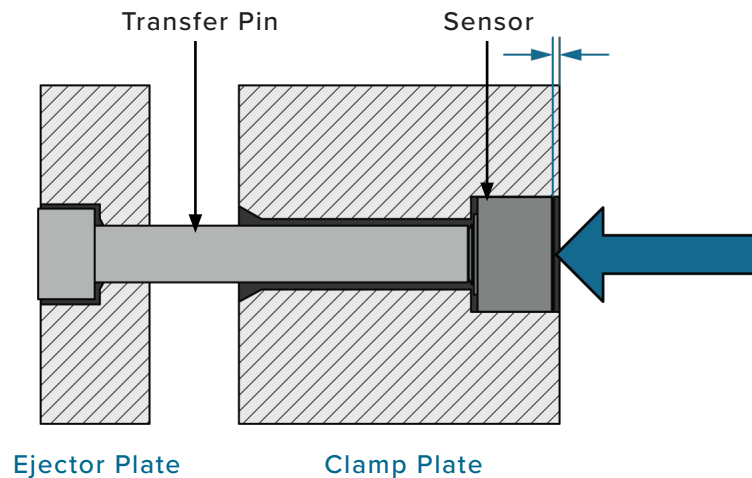

4. Flush Test (Full Stack)

With the sensor, ejector, and transfer pin installed, and the ejector plate in the injection position, fixed towards clamp plate, the ejector pin should be flush with the ejector plate/cavity surface.

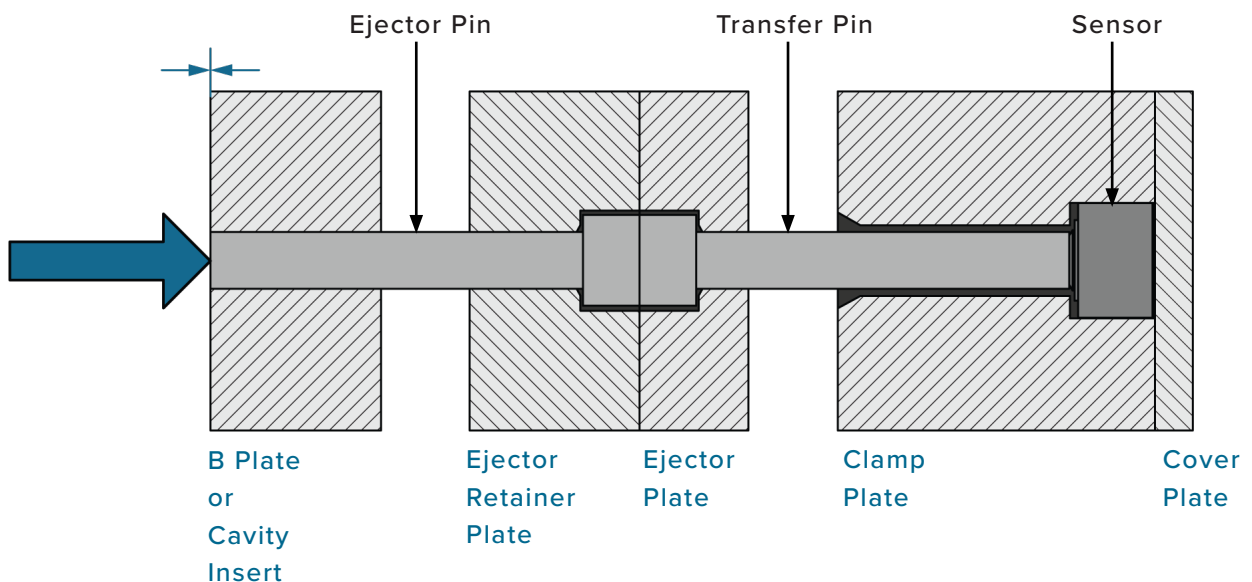

POST-ASSEMBLY CHECKS

Verify that the each sensor, transfer pin, and ejector pin pocket is machined correctly.

1. Protrusion Test (without sensor)

With the ejector and transfer pins installed, the ejector plate in injection position, and the ejector plate fixed towards clamp plate, press the ejector and transfer pin together, towards the cavity; the ejector pin should protrude 0.008–0.01” (0,2–0,3 mm).

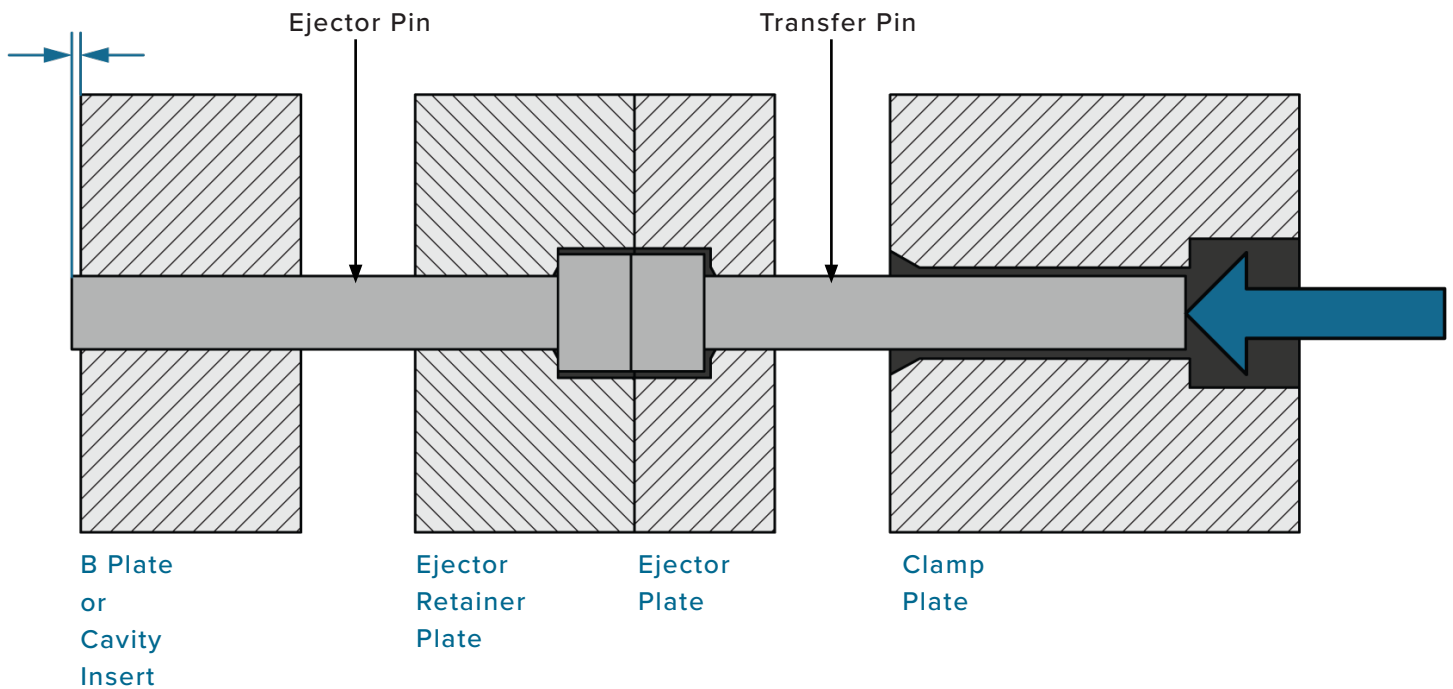

SENSOR INSTALLATION CHECK—CLAMP PLATE (HEAD-TO-HEAD) INSTALLATION (continued)

2. Indentation Test (without sensor)

With the ejector and transfer pins installed, the ejector plate in the injection position, and the ejector plate fixed towards clamp plate, press the ejector and transfer pin together, away from the cavity; the ejector pin should recess in the ejector plate 0.008–0.01" (0,2–0,3 mm).

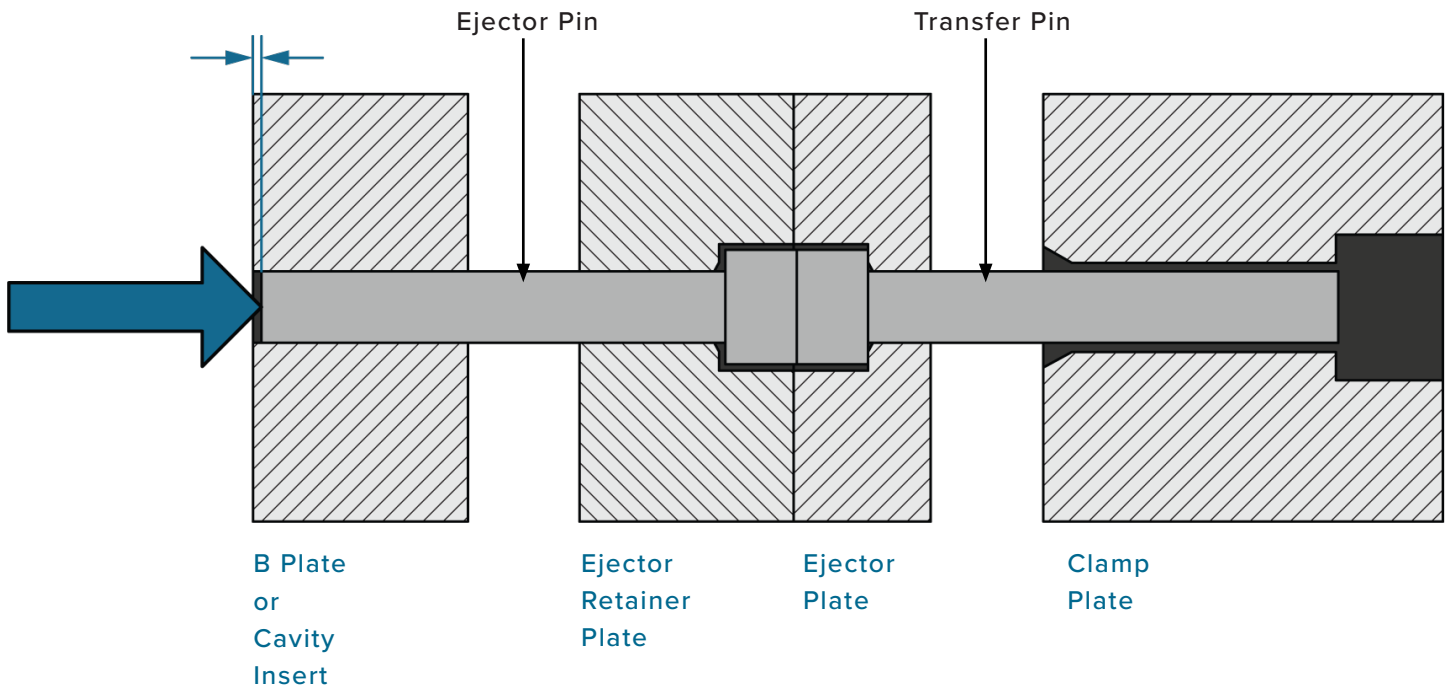

3. Flush Test (with sensor)

With the sensor, ejector, and transfer pin installed, and the ejector plate in the injection position, fixed towards clamp plate, the ejector pin should be flush with the ejector plate/ cavity surface.

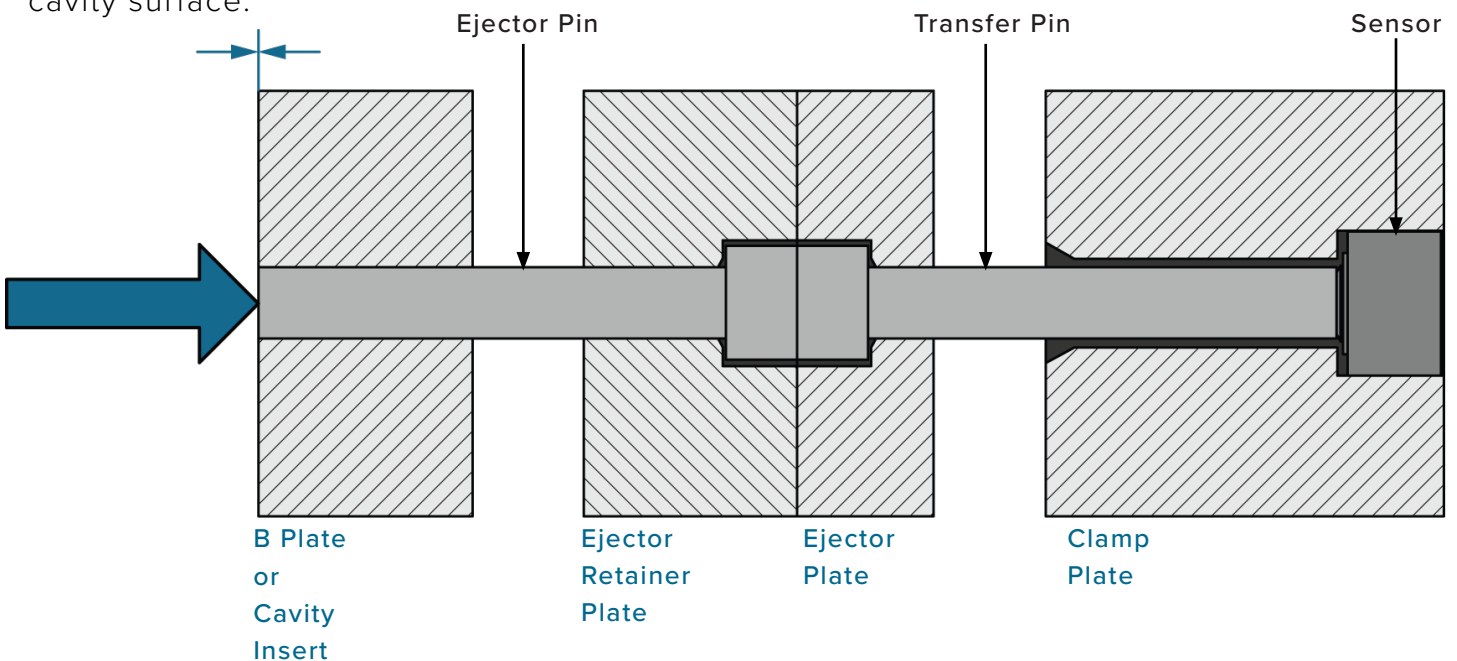

SENSOR INSTALLATION CHECK—EJECTOR PLATE INSTALLATIONS

Verify that the each sensor, transfer pin, and ejector pin pocket is machined correctly.

PRE-ASSEMBLY CHECKS

1. Indentation Test (with Ejector Pin)

With the ejector pin installed, push on the ejector pin; verify the clearance of 0.012” (0,3 mm (or 1/5 part thickness)) exists between the bottom of the ejector pin head and the ejector plate surface.

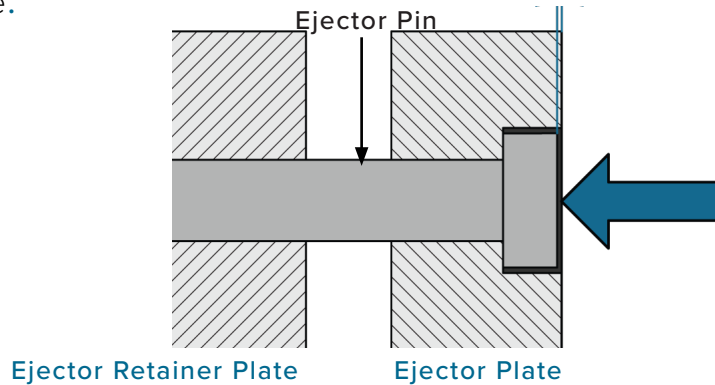

2. Flush Test (with Sensor)

With the sensor installed in the ejector retainer plate, verify that the counterbore depth equals (0,5mm) (if needed) and the counterbore diameter is larger than the ejector pin head. The sensor head should be flush with the ejector retainer plate.

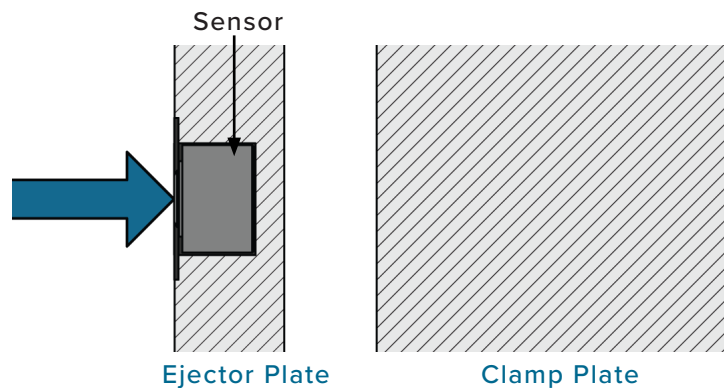

POST-ASSEMBLY CHECK

1. Flush Test (Full Stack)

With the sensor and ejector pin installed, and the ejector plate in the injection position, fixed towards clamp plate, the ejector pin should be flush with the ejector plate/cavity surface.

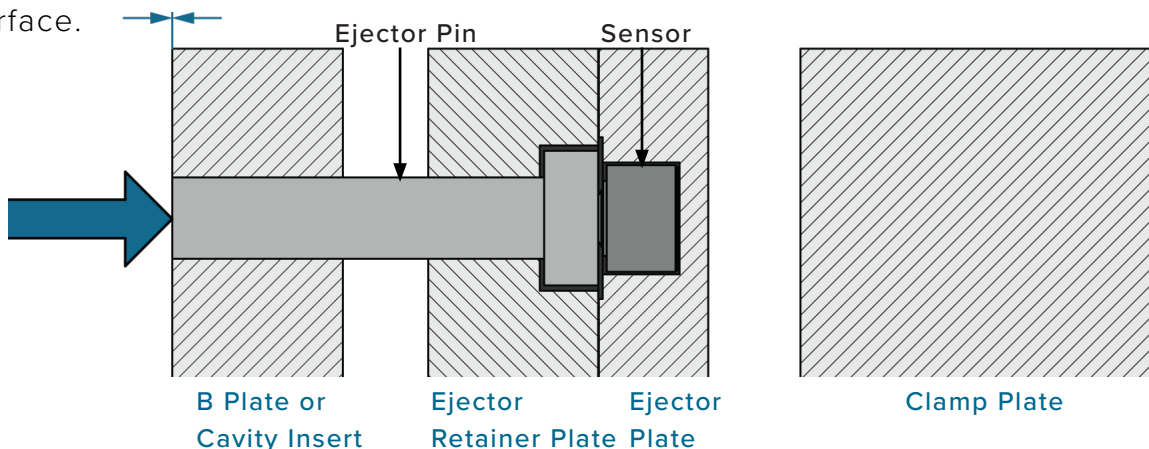

SENSOR INSTALLATION CHECK—STATIC PIN INSTALLATIONS

Verify that the each sensor and static pin pocket is machined correctly.

1. Protrusion Test (without sensor)

With only the static pin installed, push on the static pin; verify the pin protrudes clearance above the pin head equal to $\frac{1}{5}$ th of the part thickness at pin location if part thickness is less than or equal to 0.06" (1,5 mm), or 0.012" (0,3 mm) if the part thickness at pin location is greater than 0.06" (1,5 mm).

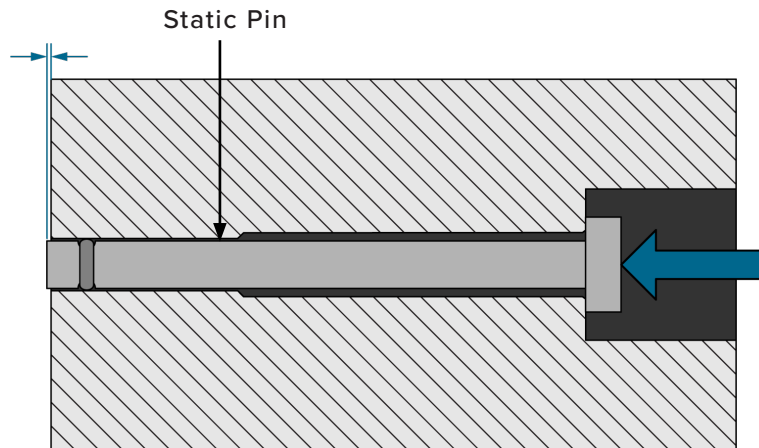

2. Flush Test (with sensor)

With the plates disassembled, sensor and pin in place, and cover plate removed, the end of the static pin should be flush with the plate surface.

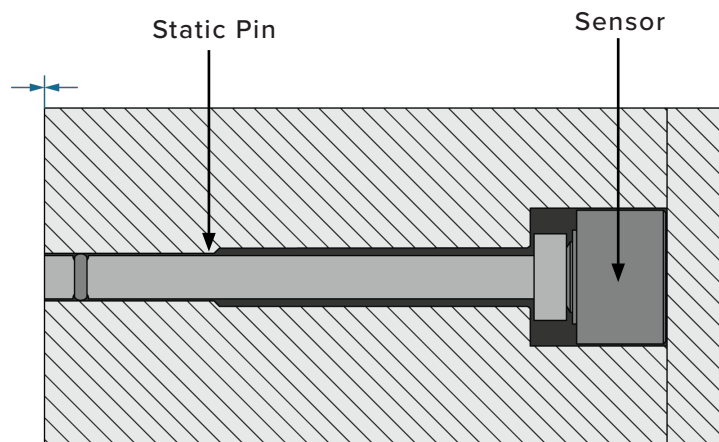

CLEANING & DRIFT

REGULAR CLEANING

Pull sensors from the mold and clean out the pockets and channels when a mold is pulled for preventative maintenance. Sensors, connectors, and cables must be installed in areas free from oil, dirt, grime, and grease.

RJG, Inc. recommends the following cleaners:

- MicroCare MCC-CCC Contact Cleaner C
- MicroCare MCC-SPR SuprClean™
- Miller-Stephenson MS-730L Contact Re-Nu®

DRIFT

Piezoelectric sensors can drift negative (-) or positive (+). The acceptable drift specification for RJG piezoelectric sensors is 20 pC/minute. The easiest place to monitor this is the eDART “Sensor Locations” screen. Drift of ± 20 pC in sixty seconds indicates abnormal drift. The cause of “Drift” is dirty/contaminated connections. This could be any of the connections from the sensor to the eDART.

Properly clean all connection points with an electronics grade contact cleaner. Allow the sensors and cables to air-dry before reconnecting them. Do not blow them out with a “shop” air line as this air usually contains oil and other contaminants.

If drift continues, clean the sensors out again with electronics grade cleaner then bake them in an oven to remove the contaminants (same method used at RJG). It is recommended to bake the sensors/ cables at 100 °C for sixty minutes.

If continuing to experience drift after this, please contact RJG Sales for pricing and lead time on replacement items.

TESTING & CALIBRATION

Follow all instructions and recommendations for individual sensor testing and calibration for optimal operation.

SENSOR TESTING

1. Sensor eValuator

The Sensor eValuator provides diagnostics on typical sensor problems such as sensor drift, preload, and zero shift, and can also detect sensor installation errors caused by improper pocket dimensions, damaged wires, and damaged sensor heads. A test report with sensor configuration can be emailed or printed from the device. This device allows testing of up to thirty-two sensors at one time and can verify that a force was applied to the sensor.

2. eDART Software—Raw Data Viewer

The eDART Raw Data Viewer displays the status of the sensor, either Valid, No Reply, Stale, or Invalid.

- A Valid sensor has raw counts that change when force is applied to the sensor; this indicates a properly working sensor.
- A No Reply sensor is not communicating with the eDART; the sensor may be unplugged.
- A Stale sensor indicates a sensor that is unused.
- An Invalid sensor will indicate a Failure of either Over-range (Ovrng) or Under-range (Undrng). The Ovrng indicates the sensor’s calibration has changed too far in a positive direction, outside of the upper specification. The Undrng indicates that the sensor’s calibration has changed too far in a negative direction, and the sensor may report a number below zero when load is applied.

WARRANTY

RJG, INC. STANDARD THREE-YEAR WARRANTY

RJG, Inc. is confident in the quality and robustness of the 9204 sensors, and so are offering a three-year warranty on all RJG sensors. RJG's cavity pressure sensors are guaranteed against defects in material and workmanship for three years from the original date of purchase. The warranty is void if it is determined that the sensor was subjected to abuse or neglect beyond the normal wear and tear of field use, or in the event the sensor has been opened by the customer. This new warranty policy is the most generous offered in the cavity pressure sensor industry, with one year being the most common.

PRODUCT DISCLAIMER

RJG, Inc. is not responsible for the improper installation of this equipment, or any other equipment RJG manufactures.

Proper RJG equipment installation does not interfere with original equipment safety features of the machine. Safety mechanisms on all machines should never be removed.

INSTALLATION ERRORS

EJECTOR PIN ISSUES

1. Pin size, expected pressure, and/or expected temperature not appropriate for selected sensor.

- Refer to "Sensor and Ejector Pin Size" on page 2.

2. Ejector pin is located behind mold surface with angle greater than 30° (1 at right).

- Angles greater than 30° cause excessive side-load friction and influence sensor accuracy.

3. Pin is engraved on head (2 at right).

- Pin heads must remain flat. Engrave pins on the side if necessary.

4. Ejector pin is contoured convexly (3 at right).

- The ejector pin must not be contoured convexly. The convex shape deflects pressure off of the pin similar to a +30° angle, preventing the pin from properly transferring cavity pressure to the sensor head, thus creating an inaccurate reading. Beyond 30°, force is lost to friction as the pin is directed sideways into the mold steel instead of directly back onto the sensor. This effect will be magnified by smaller pins that are subjected to lower forces.

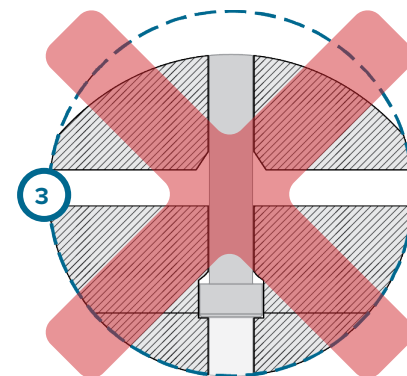
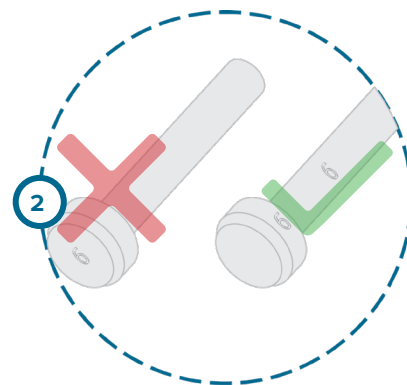
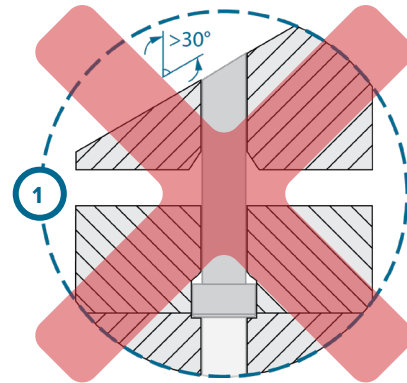

INSTALLATION ERRORS (continued)

SENSOR HEAD ISSUES

1. Ejector Pin head diameter is larger than sensor pocket diameter (1 at right).

- Counterbore the ejector plate, or chamfer the pin head to ensure that the pin rests only on the sensor nub.

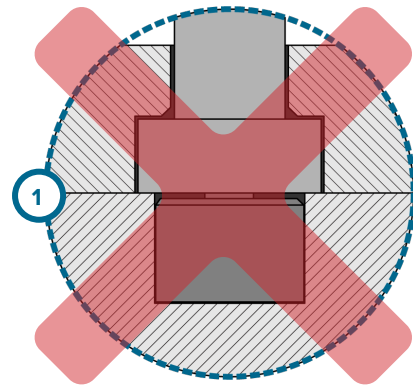

2. Sensor head is installed incorrectly (2 at right).

- The sensor nub must face the ejector pin. DO NOT install the sensor head upside-down.

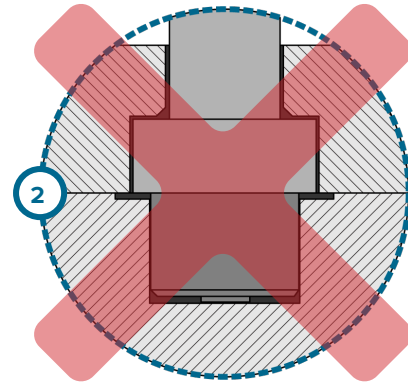

3. Sensor pocket surface is not smooth (3 at right).

- The mold surface must have a finish of $\sqrt{32}$ or better; the sensor pocket must have a smooth surface.

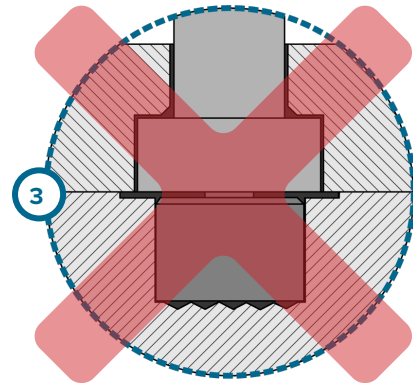

4. Sensor and ejector pin are not perpendicular (4 at right).

- The sensor and ejector pin must be perpendicular.

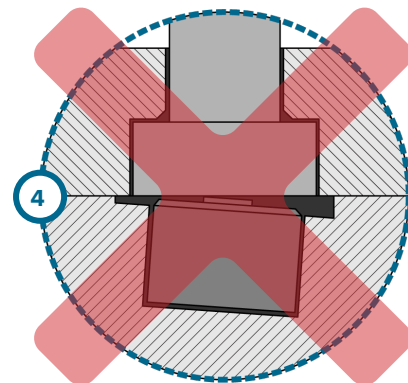

INSTALLATION ERRORS (continued)

CASE AND CABLE ISSUES

1. Sensor cable is pinched during mold assembly (1 at right).
2. Sensor case or adapter is mounted on surface that exceeds temperature rating.
 - Do not mount the Lynx case or adapter on surface that exceeds the recommended temperature rating. Contact RJG, Inc. Customer support for high-temperature applications.

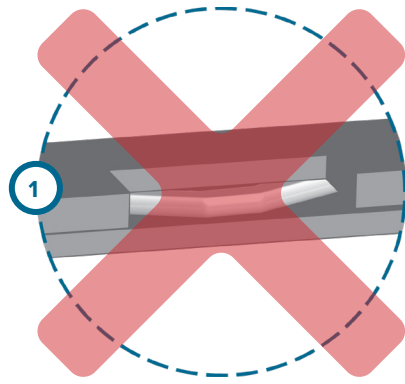

3. Lynx case or adapter is drilled to accommodate alternate mounting (2 at right).
 - NEVER drill the Lynx case or adapter. Failure to comply will result in damage or destruction to equipment and void of warranty.

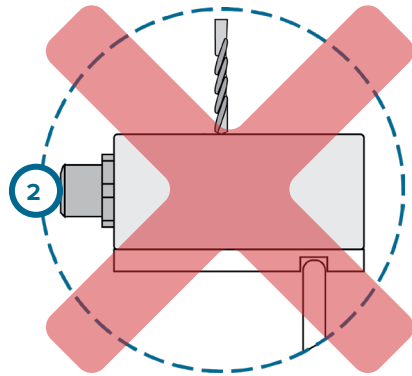

4. Orientation of Lynx connector on Lynx case or adapter is altered from OEM (3 at right).
 - The Lynx connector on the Lynx case/ adapter is keyed. DO NOT attempt to change key orientation by loosening or tightening the Lynx connector on the Lynx case or adapter. Failure to comply will result in damage to equipment and void of warranty.

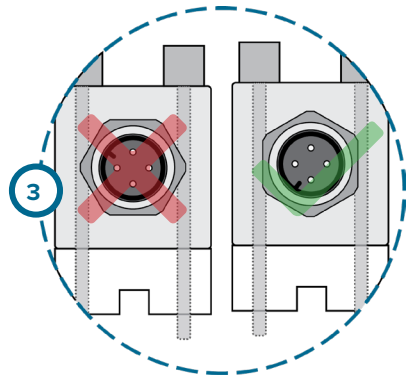

COMMON ERRORS

1. Slow sensor drift reading.

A sensor reading that slowly rises or falls (positive or negative) from the set zero value.



2. Fast sensor drift/invalid reading.

A sensor reading that quickly or rises or falls (positive or negative) from the set zero value, possibly so much that the reading becomes invalid.

3. No sensor/eDART communication.

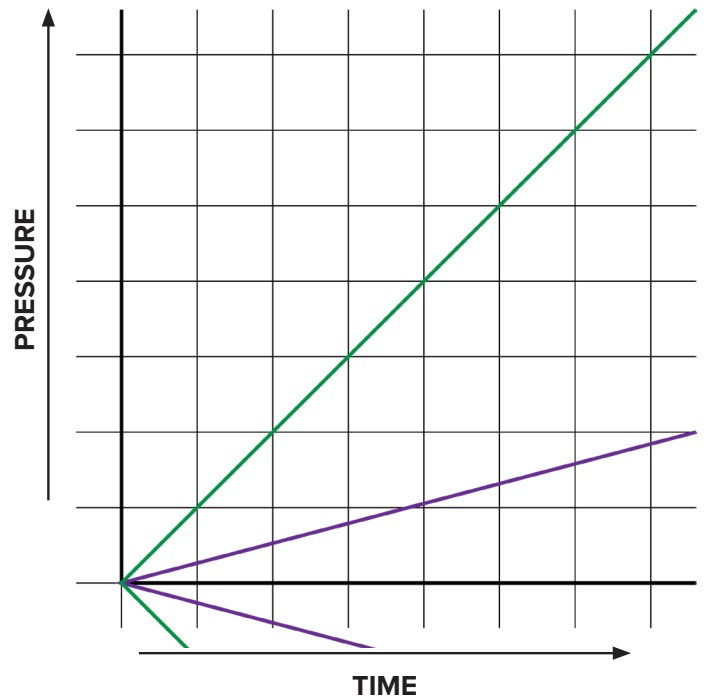
The sensor reading cannot be obtained by the eDART.



Piezoelectric Sensor Drift Type Graph	
	Fast Drift/Invalid
	Slow Drift

COMMON ERRORS (continued)

SLOW SENSOR DRIFT READING

If the sensor reading will not remain steady and drifts positive or negative, the sensor, cables, or adapter connectors may be contaminated. To identify the connector(s) with contamination, perform the following:

1. Disconnect sensor from 1645 or C-PZ/1645 cable and clean ends; if reading continues to drift, continue to next step.
2. Disconnect the 1645 or C-PZ/1645 from the sensor connector or adapter and clean ends; if the reading continues to drift, continue to next step.
3. If applicable, disconnect cable from the sensor connector and clean end and connector; if the reading continues to drift, continue to next step.
4. If applicable, disconnect cable from adapter and clean end and connector; if the reading continues to drift, continue to next step.

If the sensor reading continues to drift after the above troubleshooting steps are completed, either the sensor, cables, connector, or adapter must be replaced.

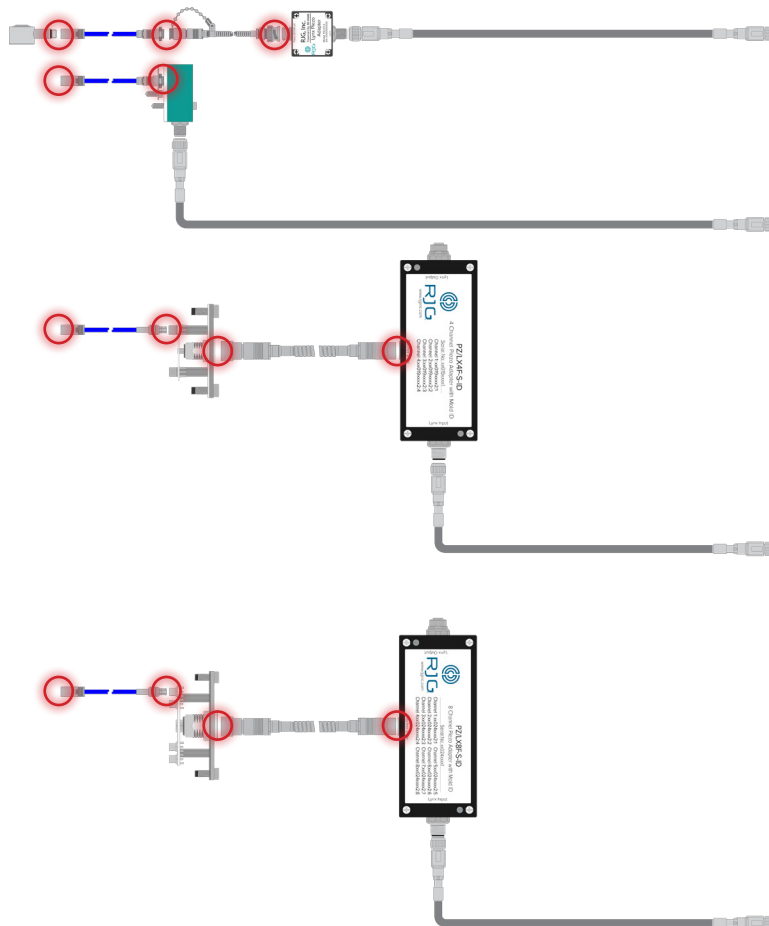

COMMON ERRORS (continued)

FAST SENSOR DRIFT/INVALID READING

If the sensor reading drifts quickly and becomes invalid, the sensor, cables, or adapter connectors may be heavily contaminated, or the adapter may have failed. To identify the connector(s) with contamination, perform the following:

1. Disconnect sensor from 1645 or C-PZ/1645 cable and clean ends; if reading continues to drift, continue to next step.
2. Disconnect the 1645 or C-PZ/1645 from connector or adapter and clean ends; if the reading continues to drift, continue to next step.
3. If applicable, disconnect cable from the sensor connector and clean end and connector; if the reading continues to drift, continue to next step.
4. If applicable, disconnect cable from the adapter and clean end and connector; if the reading continues to drift, continue to next step.

If the sensor reading continues to drift or remains invalid after the above troubleshooting steps are completed the adapter must be replaced.

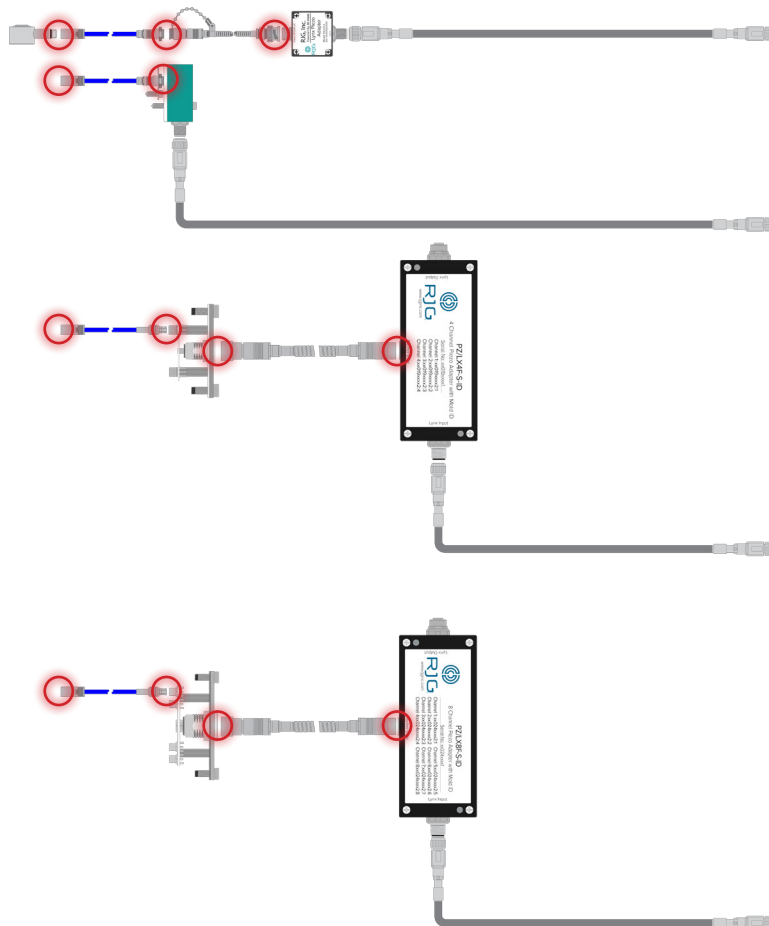

COMMON ERRORS *(continued)*

SENSOR DOES NOT COMMUNICATE WITH EDART

If the eDART is unable to establish communication with the sensor, the cables or adapter may have failed. To identify the failed component, perform the following;

1. Replace the 1645 or C-PZ/1645 sensor cable with working cable; test sensor operation. If communication remains non-existent, continue to next step.
2. Replace the sensor connector cable with working cable; test sensor operation. If communication remains non-existent, continue to next step.
3. If applicable, replace the sensor adapter cable with working cable; test sensor operation. If communication remains non-existent, continue to next step.
- 4.
5. Replace the CE-LX5 Lynx cable with working cable; test the sensor operation.

If the eDART cannot establish communication after these steps, the connector has failed and must be replaced.

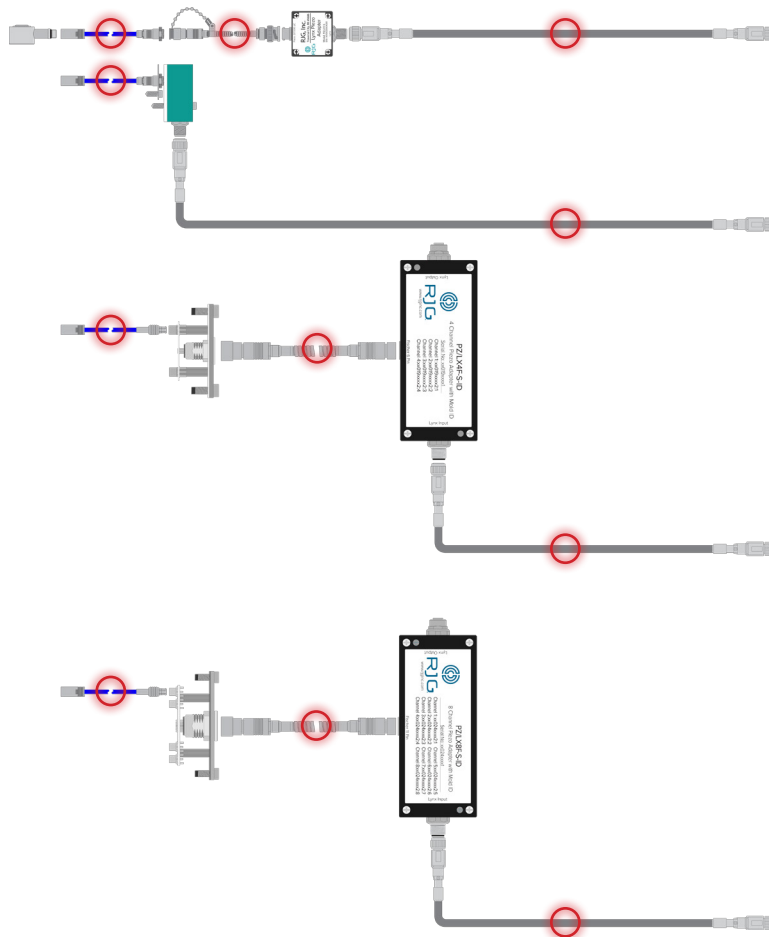

CUSTOMER SUPPORT

Contact RJG's Customer Support team by phone or email.

RJG, Inc. Customer Support

P: 800.472.0566 (Toll Free)

P: +1.231.933.8170

email: globalcustomersupport@rjginc.com

www.rjginc.com/support

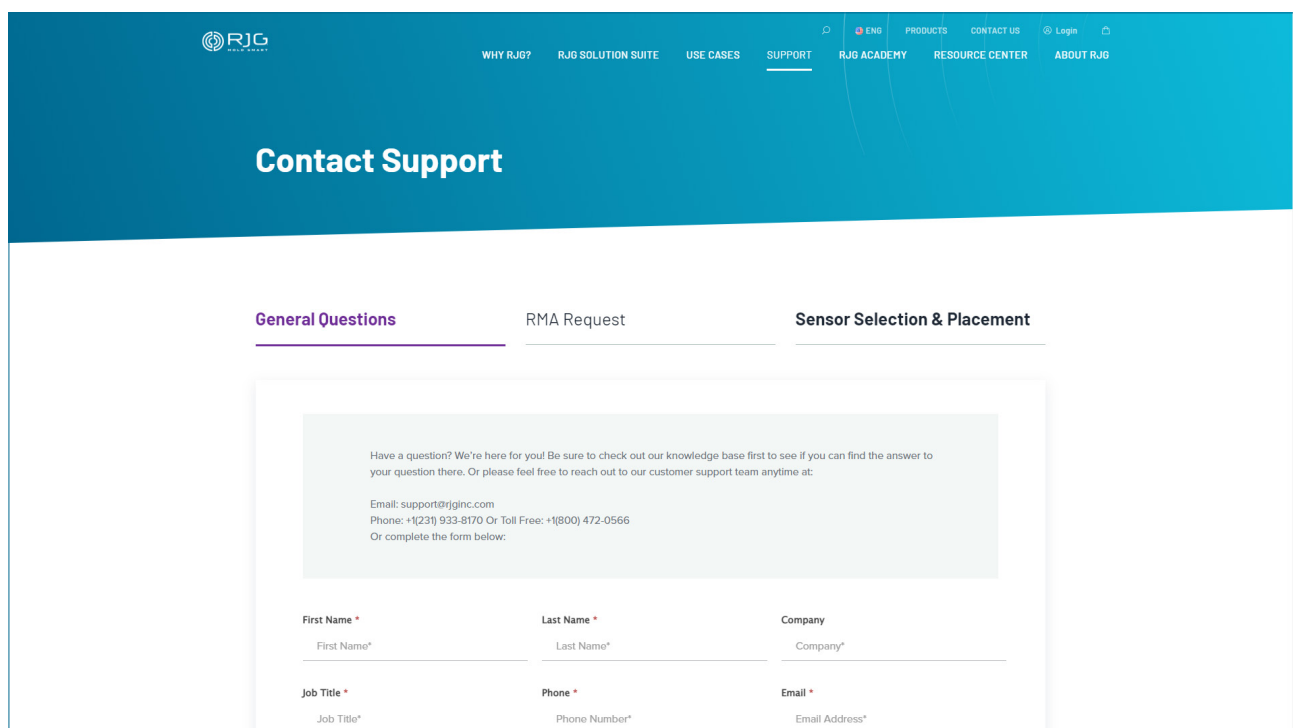

The screenshot shows the 'Contact Support' page on the RJG website. The page has a blue header with the RJG logo and navigation links: WHY RJG?, RJG SOLUTION SUITE, USE CASES, SUPPORT (highlighted), RJG ACADEMY, RESOURCE CENTER, and ABOUT RJG. There are also links for ENG, PRODUCTS, CONTACT US, and Login. Below the header, the page is titled 'Contact Support' and has three tabs: 'General Questions' (selected), 'RMA Request', and 'Sensor Selection & Placement'. The 'General Questions' tab contains a text box with the following text: 'Have a question? We're here for you! Be sure to check out our knowledge base first to see if you can find the answer to your question there. Or please feel free to reach out to our customer support team anytime at: Email: support@rjginc.com Phone: +1(231) 933-8170 Or Toll Free: +1(800) 472-0566 Or complete the form below:'. Below this text is a form with six input fields: 'First Name *', 'Last Name *', 'Company', 'Job Title *', 'Phone *', and 'Email *'. Each field has a corresponding label and a placeholder text.

RELATED PRODUCTS

The 9204 is compatible with other RJG, Inc. products for use with the *eDART* and CoPilot process control and monitoring systems.

COMPATIBLE PRODUCTS

LYNX CABLES CE-LX5

The Lynx sensor cable (1 at right) is a polypropylene-coated cable suited for the heat and stress found in injection molding environments. The cable is available in lengths 12–473" (0,3–12,0 m), and can be ordered with straight or 90° fittings. One CE-LX5 is required to interface the single-channel sensor adapters LP/LX1-M or PZ/LX1-S with the *eDART* and CoPilot systems.



SINGLE-CHANNEL PIEZOELECTRIC SENSOR CABLE 1645

The single-channel piezoelectric sensor cable 1645 (2 at right) is a PTFE/FEP coaxial cable suited for the injection molding environment. The cable is available in several lengths from 8–79" (0,2–2,0 m). One 1645 is required to interface the 9204 with a Lynx single-channel piezoelectric sensor adapter and the *eDART* and CoPilot systems.



MULTI-CHANNEL PIEZOELECTRIC SENSOR CABLE C-PZ/1645

The multi-channel piezoelectric sensor cable C-PZ/1645 (3 at right) is a PTFE/FEP coaxial cable suited for the injection molding environment. The cable is available in several lengths from 8–79" (0,2–2,0 m). One C-PZ/1645 is required to interface each 9204 with a Lynx multi-channel piezoelectric sensor connector and the *eDART* and CoPilot systems.



SIMILAR PRODUCTS

RJG, Inc. offers a wide array of cavity pressure sensors for each application—piezoelectric, strain gage, single-channel, multi-channel, and digital.

LYNX SINGLE-CHANNEL STRAIN GAGE BUTTON SENSOR LS-B-127-50/125/500/2000

The LS-B-127-50/125/500/2000 line of sensors (1 at right) from RJG, Inc. are single-channel, digital strain gage, indirect (under-pin), 0.50" (12,7 mm) button-style cavity pressure sensors that can withstand forces up to 50 lb. (0.22 kN), 125 lb. (0.56 kN), 500 lb. (2.22 kN), and 2,000 lb. (8.9 kN) and temperatures up to 250 °F (120 °C—standard sensors) or 425 °F (220 °C—high-temperature sensors).

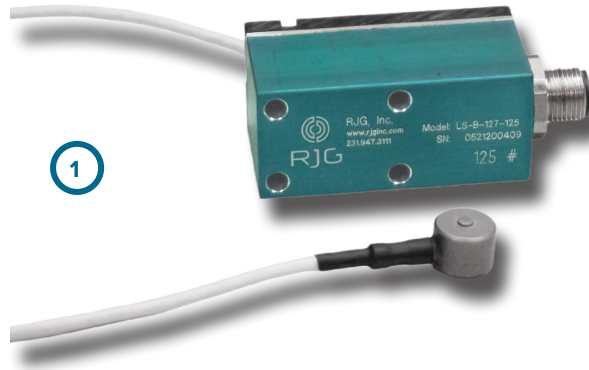

SINGLE/MULTI-CHANNEL 3.5 MM PIEZOELECTRIC SENSOR 9210

The 9210 single or multi-channel 0.14" (3,5 mm) piezoelectric sensor (2 at right) is a button-style cavity pressure sensor that can withstand forces up to 56 lb. (250 N) and temperatures up to 392 °F (200 °C).



SINGLE/MULTI-CHANNEL 6 MM PIEZOELECTRIC SENSOR 9211

The 9211 single or multi-channel 0.24" (6,0 mm) piezoelectric sensor (3 at right) is a button-style cavity pressure sensor that can withstand forces up to 562 lb. (2.5 kN) and temperatures up to 392 °F (200 °C).



LOCATIONS / OFFICES

USA

RJG USA (HEADQUARTERS)

3111 Park Drive
Traverse City, MI 49686
P +01 231 947-3111
F +01 231 947-6403
sales@rjginc.com
www.rjginc.com

ITALY

NEXT INNOVATION SRL

Milano, Italy
P +39 335 178 4035
sales@it.rjginc.com
it.rjginc.com

MEXICO

RJG MEXICO

Chihuahua, Mexico
P +52 614 4242281
sales@es.rjginc.com
es.rjginc.com

SINGAPORE

RJG (S.E.A.) PTE LTD

Singapore, Republic of
Singapore
P +65 6846 1518
sales@swg.rjginc.com
en.rjginc.com

FRANCE

RJG FRANCE

Arnithod, France
P +33 384 442 992
sales@fr.rjginc.com
fr.rjginc.com

CHINA

RJG CHINA

Chengdu, China
P +86 28 6201 6816
sales@cn.rjginc.com
zh.rjginc.com

GERMANY

RJG GERMANY

Karlstein, Germany
P +49 (0) 6188 44696 11
sales@de.rjginc.com
de.rjginc.com

KOREA

CAEPRO

Seoul, Korea
P +82 02-2113-1870
sales@ko.rjginc.com
www.caepro.co.kr

IRELAND/UK

RJG TECHNOLOGIES, LTD.

Peterborough, England
P +44(0)1733-232211
info@rjginc.co.uk
www.rjginc.co.uk