

# PRODUCT MANUAL

FLUSH-MOUNT 2.5 MM PIEZOELECTRIC  
CAVITY PRESSURE SENSOR

**6159**





# PRODUCT MANUAL

## FLUSH-MOUNT 2.5 MM PIEZOELECTRIC CAVITY PRESSURE SENSOR

### 6159

#### INTRODUCTION

DISCLAIMER	V
PRIVACY	V
ALERTS	V
ABBREVIATIONS	V

#### PRODUCT DESCRIPTION

APPLICATIONS	1
FLUSH-MOUNT CAVITY PRESSURE SENSORS	1
SINGLE-CHANNEL	1
MULTI-CHANNEL	1
OPERATION	1
PIEZOELECTRIC SENSORS	1
DIMENSIONS	2
COMPATIBLE CABLES	2
CABLE LENGTHS	2

#### INSTALLATION

INSTALLATION OVERVIEW	3
RETAINING NUT INSTALLATION	3
RETAINING SLEEVE INSTALLATION	3
INSTALLATION SPECIFICATIONS—RETAINING NUT	4
PLATE THICKNESS	5
SENSOR TIP POCKET	5
SENSOR BODY POCKET	5
RETAINING NUT POCKET	5

# PRODUCT MANUAL

## FLUSH-MOUNT 2.5 MM PIEZOELECTRIC CAVITY PRESSURE SENSOR

### 6159

#### INSTALLATION (CONTINUED)

INSTALLATION SPECIFICATIONS—RETAINING SLEEVE	6
PLATE THICKNESS FOR CABLE CLEARANCE	7
SENSOR TIP POCKET	7
SENSOR BODY AND RETAINING SLEEVE POCKET	7
SENSOR CABLE	8
CABLE CHANNEL	8
EXCESS CABLE POCKET	8
SENSOR CABLE BEND	8
SENSOR POCKET CHECK	8
SENSOR TIP MACHINING	9
OVERVIEW	9
DRY GRIND SPECIFICATIONS	9
CONTOURING SPECIFICATIONS	9
ANGLE SPECIFICATIONS	9
ADDITIONAL MACHINING	10
FLUSH MOUNT SENSOR KEYING	10
SENSOR KEYING A NEW INSTALLATION	10
SENSOR KEYING A PREVIOUS POCKET	10

# PRODUCT MANUAL

## FLUSH-MOUNT 2.5 MM PIEZOELECTRIC CAVITY PRESSURE SENSOR

### 6159

#### MAINTENANCE

CLEANING & DRIFT	11
REGULAR CLEANING	11
DRIFT	11
TESTING & CALIBRATION	11
SENSOR TESTING	11
WARRANTY	12
RJG, INC. STANDARD THREE-YEAR WARRANTY	12
PRODUCT DISCLAIMER	12

#### TROUBLESHOOTING

COMMON ERRORS	13
SENSOR HEAD ISSUES	13
CABLE ISSUES	13
SENSOR DRIFT	14
SLOW SENSOR DRIFT READING	15
FAST SENSOR DRIFT/INVALID READING	16
SENSOR DOES NOT COMMUNICATE WITH eDART/COPILOT	17
CUSTOMER SUPPORT	18

# PRODUCT MANUAL

## FLUSH-MOUNT 2.5 MM PIEZOELECTRIC CAVITY PRESSURE SENSOR

### 6159

#### RELATED PRODUCTS

COMPATIBLE PRODUCTS	19
LYNX CABLES CE-LX5	19
SINGLE-CHANNEL PIEZOELECTRIC SENSOR CABLE 1645	19
MULTI-CHANNEL PIEZOELECTRIC SENSOR CABLE C-PZ/1645	19
SIMILAR PRODUCTS	20
FLUSH-MOUNT 4 MM PIEZOELECTRIC CAVITY PRESSURE SENSOR 615720	
SINGLE/MULTI-CHANNEL 3.5 MM PIEZOELECTRIC SENSOR 9210	20
SINGLE/MULTI-CHANNEL 6 MM PIEZOELECTRIC SENSOR 9211	20

## INTRODUCTION

Read, understand, and comply with all following instructions. This guide must be kept available for reference at all times.

### DISCLAIMER



Inasmuch as RJG, Inc. has no control over the use to which others may put this material, it does not guarantee that the same results as those described herein will be obtained. Nor does RJG, Inc. guarantee the effectiveness or safety of any possible or suggested design for articles of manufacture as illustrated herein by any photographs, technical drawings, and the like. Each user of the material or design or both should make his own tests to determine the suitability of the material or any material for the design as well as the suitability of the material, process, and/or design for his own particular use. Statements concerning possible or suggested uses of the material or designs described herein are not to be construed as constituting a license under any RJG, Inc. patent covering such use or as recommendations for use of such material or designs in the infringement of any patent.

### PRIVACY

Designed and developed by RJG, Inc. Manual design, format and structure copyright 2018 RJG, Inc. content documentation copyright 2018 RJG, Inc. All rights reserved. Material contained herein may not be copied by hand, mechanical, or electronic means, either whole or in part, without the express written consent of RJG, Inc. Permission will normally be granted for use in conjunction with inter-company use not in conflict with RJG's best interests.

### ALERTS

The following three alert types are used as needed to further clarify or highlight information presented in the manual:

-  **DEFINITION** *A definition or clarification of a term or terms used in the text.*
-  **NOTES** *A note provides additional information about a discussion topic.*
-  **CAUTION** *A caution is used to make the operator aware of conditions that can cause damage to equipment and/or injury to personnel.*

### ABBREVIATIONS

DIA	diameter
MIN	minimum
MAX	maximum
R.	radius





## PRODUCT DESCRIPTION

The flush-mount 2.5 mm piezoelectric cavity pressure sensor 6159 from RJG, Inc. is a single- or multi-channel sensor that can withstand forces of up to 29,000 psi (2,000 bar) and a maximum temperature of 392 °F (200 °C).

### APPLICATIONS

#### FLUSH-MOUNT CAVITY PRESSURE SENSORS

The flush-mount sensor is made of stainless steel which can be contoured, angled, and/or textured to match the cavity in which it is installed.

#### SINGLE-CHANNEL

The 6159 can be utilized in single-channel applications in conjunction with the Lynx™ mold-mount piezoelectric sensor adapter LP/LX1-M or the Lynx surface-mount piezoelectric sensor adapter PZ/LX1-S and the eDART® or CoPilot® system.

#### MULTI-CHANNEL

The 6159 can be utilized in multi-channel applications which enable either four or eight sensors to be connected outside the mold with a single cable. The Lynx four-channel piezoelectric sensor connector and adapter—PZ-4 and PZ/LX4F-S-ID—allow up to four sensor connections, while the Lynx eight-channel piezoelectric sensor connector and adapter—PZ-8 and PZ/LX8F-S-ID—allow up to eight sensor connections to the eDART or CoPilot system.

### OPERATION

#### PIEZOELECTRIC SENSORS

Piezoelectric sensors use quartz crystals to measure the deformation, or change in resistance of the force over the sensor. The measurement is carried through the sensor cable to a sensor adapter mounted on the outside of the mold.

The sensor adapter is connected to the RJG, Inc. eDART or CoPilot system, which record and display the sensor's measurements for operator aid in process monitoring and control.

## DIMENSIONS

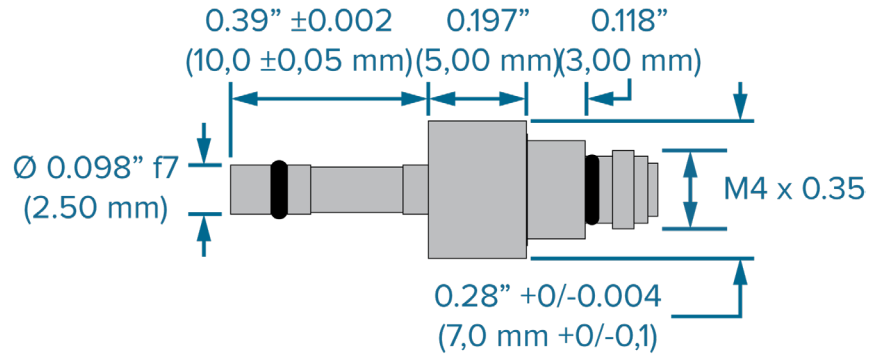

## COMPATIBLE CABLES

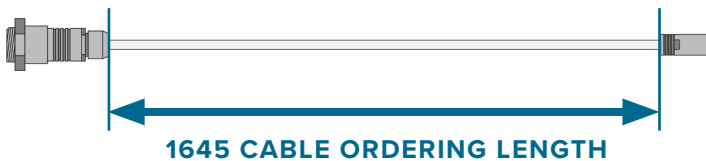

## CABLE LENGTHS

Length must be longer than needed to facilitate safe installation and removal of connector from tool to prevent tension on the lead wire; generally, 2–3” (50–75 mm) of slack is sufficient. Use good sense to determine the appropriate cable length required for each application.

	SINGLE-CHANNEL	MULTI-CHANNEL	LENGTH	
			S.I.	ENGLISH
-	C-PZ/1645-0.1	0,1 m	3.9”	
-	C-PZ/1645-0.15	0,15 m	5.9”	
1645-0.2	C-PZ/1645-0.2	0,2 m	7.90”	
-	C-PZ/1645-0.25	0,25 m	9.8”	
-	C-PZ/1645-0.3	0,3 m	11.8”	
-	C-PZ/1645-0.35	0,35 m	13.8”	
1645-0.4	C-PZ/1645-0.4	0,4 m	15.75”	
1645-0.6	C-PZ/1645-0.6	0,6 m	23.6”	
1645-0.8	C-PZ/1645-0.8	0,8 m	31.5”	
1645-1.2	C-PZ/1645-1.2	1,2 m	47.24”	
1645-1.6	C-PZ/1645-1.6	1,6 m	63”	
1645-2.0	C-PZ/1645-2.0	2,0 m	78.74”	

## INSTALLATION

The 6159 is retained in a cavity by either a nut or sleeve (purchased separately—part numbers MA-6157-NUT and MA-6157-S20).

### INSTALLATION OVERVIEW

#### RETAINING NUT INSTALLATION

The sensor is inserted into and retained in the mold by a retaining nut. The retaining nut is threaded into the mold. The sensor tip reaches through to the mold cavity surface. The tip may be machined to match the cavity's surface and/or contour prior to installation.

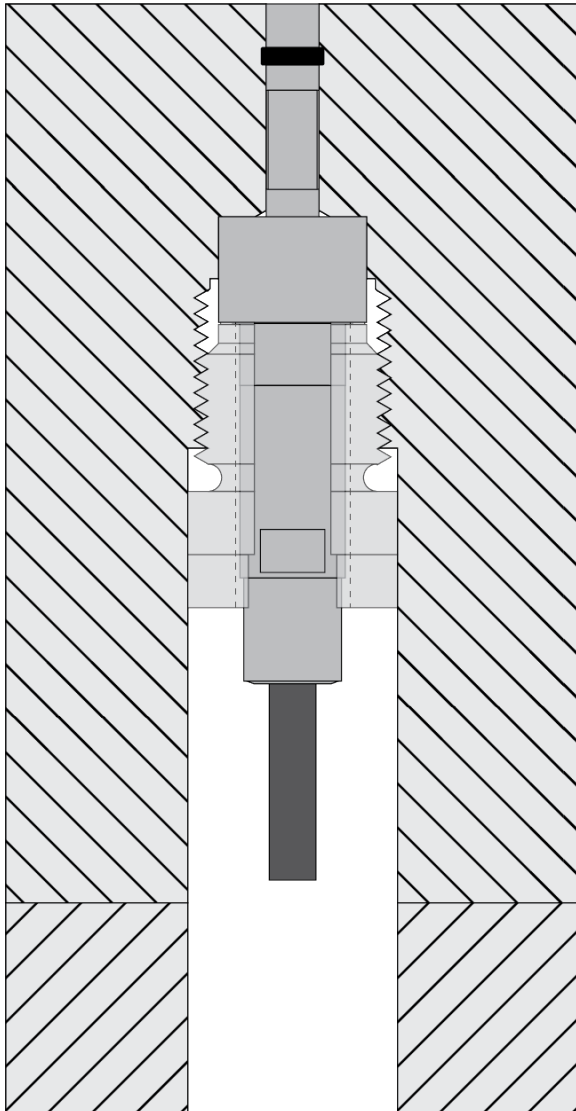

#### RETAINING SLEEVE INSTALLATION

The sensor is retained in the mold by a retaining sleeve. The retaining sleeve is fixed in the mold by a backing plate. The sensor tip reaches through to the mold cavity surface. The tip may be machined to match the cavity's surface and/or contour prior to installation.

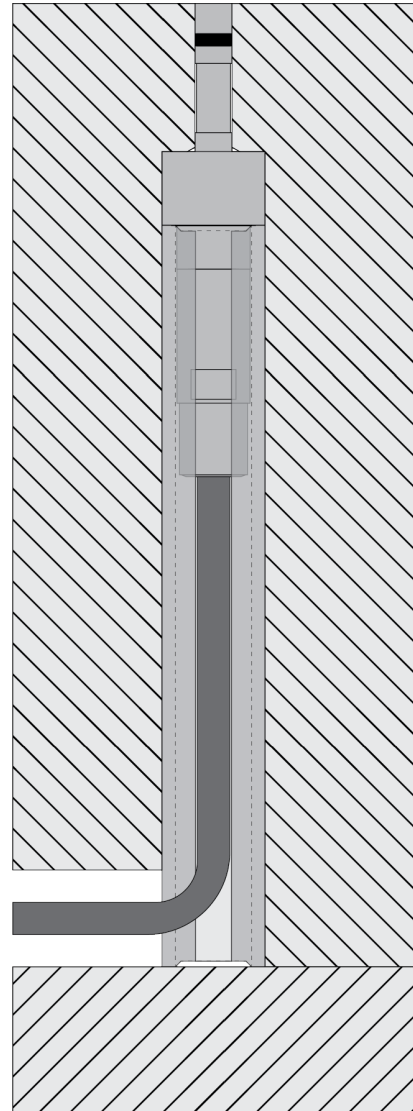

**INSTALLATION SPECIFICATIONS—RETAINING NUT**

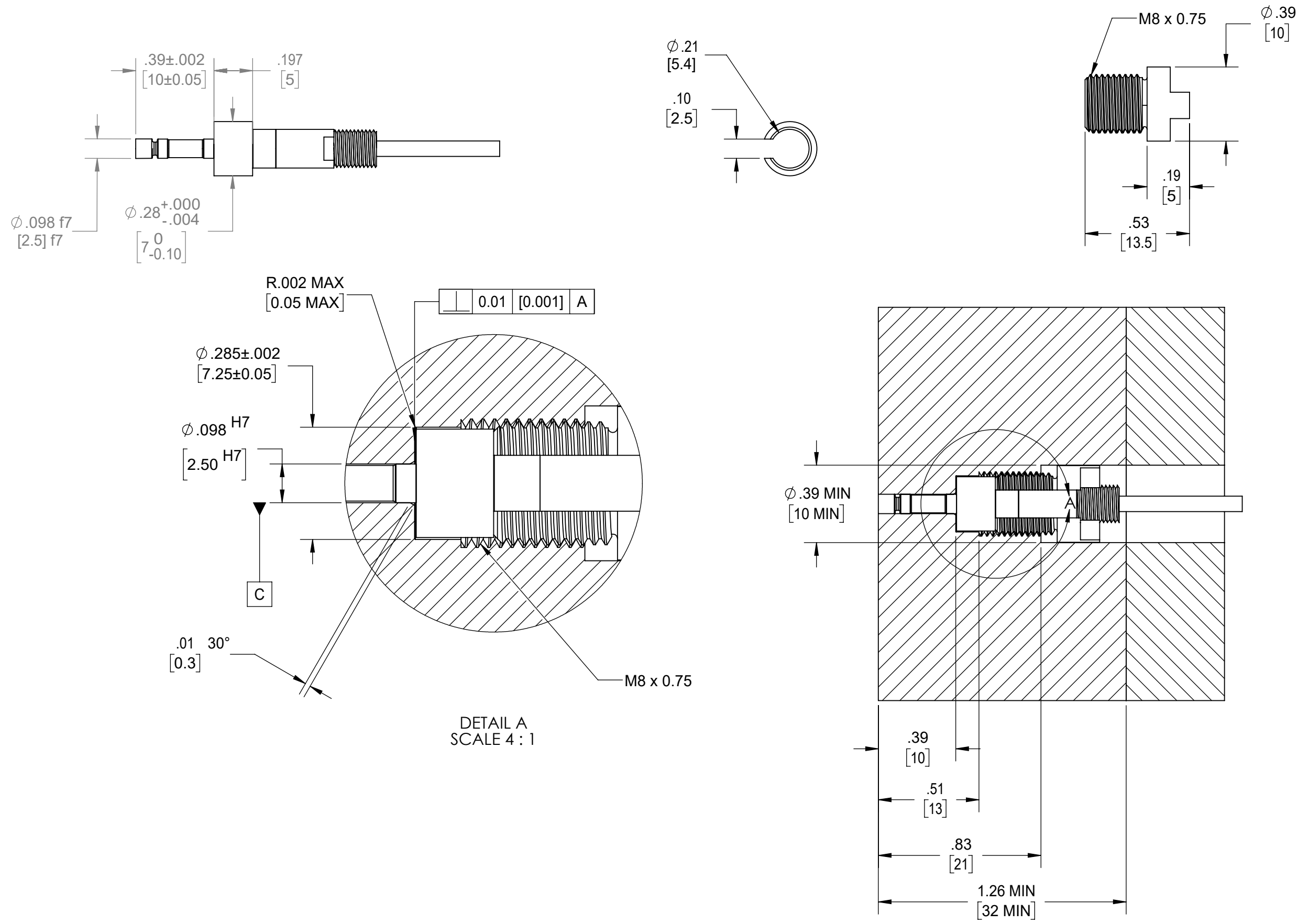

## INSTALLATION SPECIFICATIONS—RETAINING NUT (continued)

### PLATE THICKNESS

Plate thickness must be 1.26" (32,0 mm [1 at right]) MIN.

### SENSOR TIP POCKET

Machine a pocket for the sensor tip with hole basis ISO standard fit H7h6—H7h6 is a locational clearance suitable for precision location fits. The sensor should fit without binding. The sensor tip should have a surface finish of  $\sqrt{32}$  or better.

- Sensor tip  $\varnothing$  0.098" H7 (2,50 mm [2 at right]).
- Sensor tip length of 0.39" (10,0 mm [3 at right]).

### SENSOR BODY POCKET

Machine a pocket for the sensor body with hole basis H7h6. The sensor body should fit without binding.

- Sensor body pocket  $\varnothing$  0.285"  $\pm 0.002$  (7,25 mm  $\pm 0,05$  [4 at right]).
- Chamfer 30° MIN/MAX 0.01/0.02" (0,3/0,4 mm [5 at right]) where sensor tip and sensor body meet for ease of installation.

### RETAINING NUT POCKET

Drill and tap a pocket for the retaining nut:

- To sensor retaining nut pocket  $\varnothing$  0.39" MIN (10,0 mm [6 at right]).
- Sensor retaining nut pocket M8 x 0.75 [7 at right]).

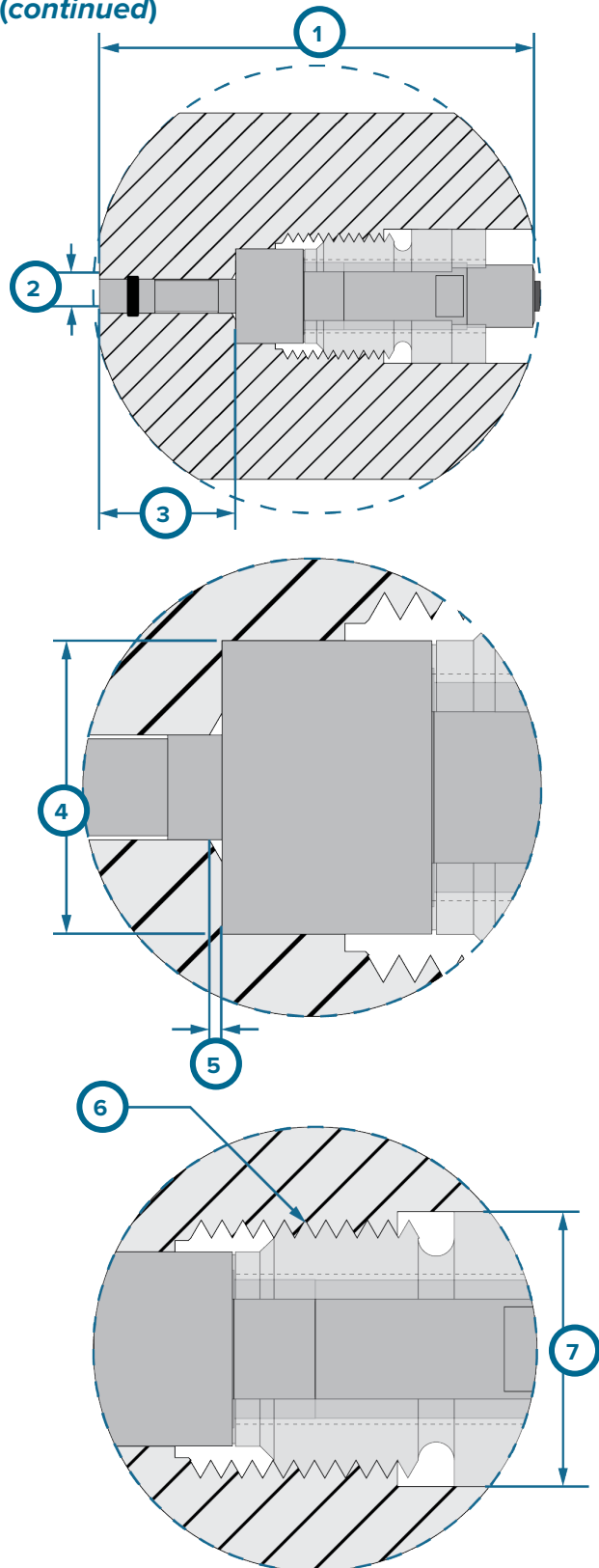

1	1.26" (32,0 mm)	5	Chamfer 30° 0.01/0.02" (0,3/0,4 mm) MIN/MAX
2	$\varnothing$ 0.098" H7 (2,50 mm H7) MIN	6	$\varnothing$ 0.39" (10,0 mm) MIN
3	0.39" (10,0 mm)	7	M8 x 0.75
4	$\varnothing$ 0.285" $\pm 0.002$ (7,25 mm $\pm 0,05$ )		

**INSTALLATION SPECIFICATIONS—RETAINING SLEEVE**

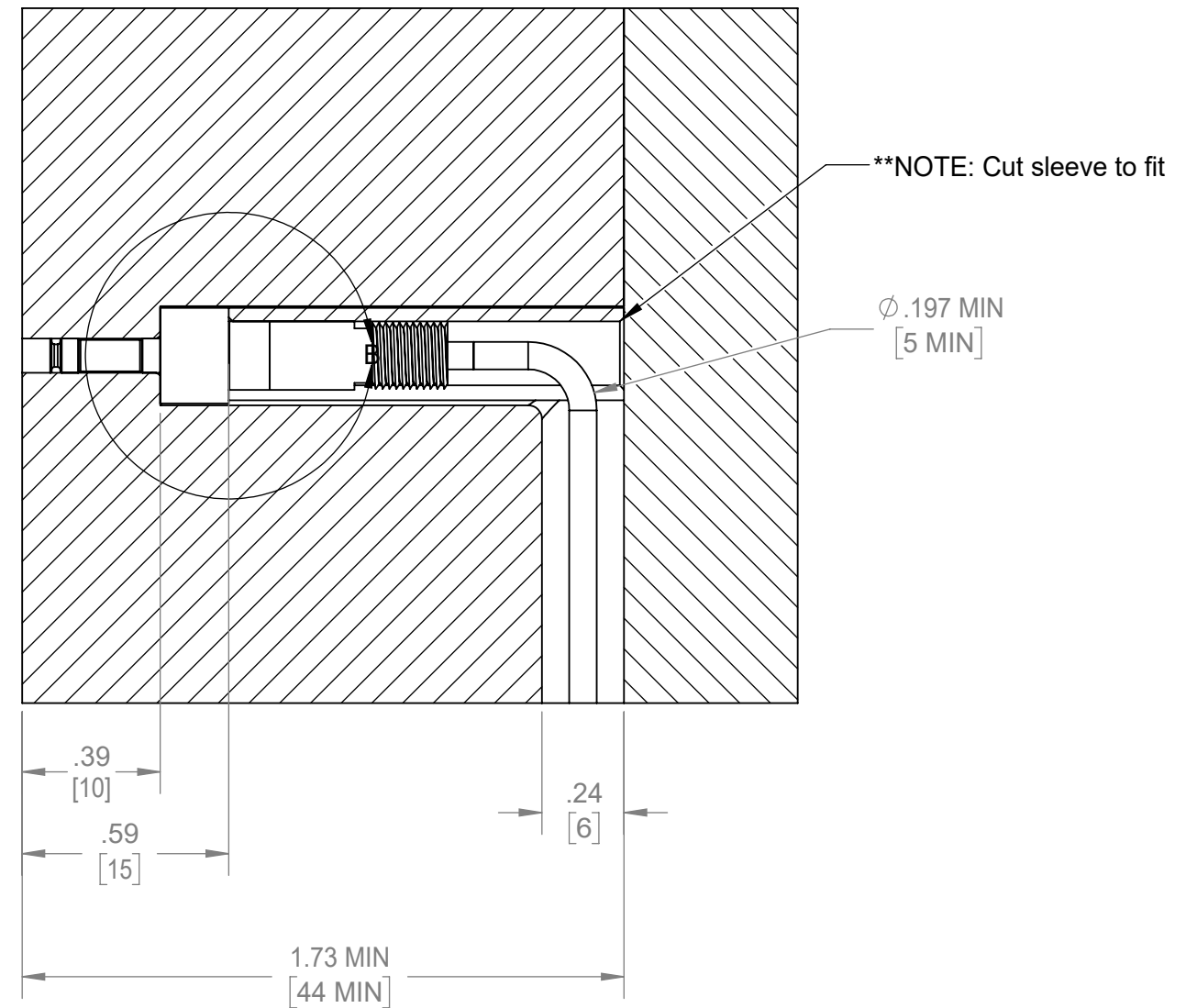
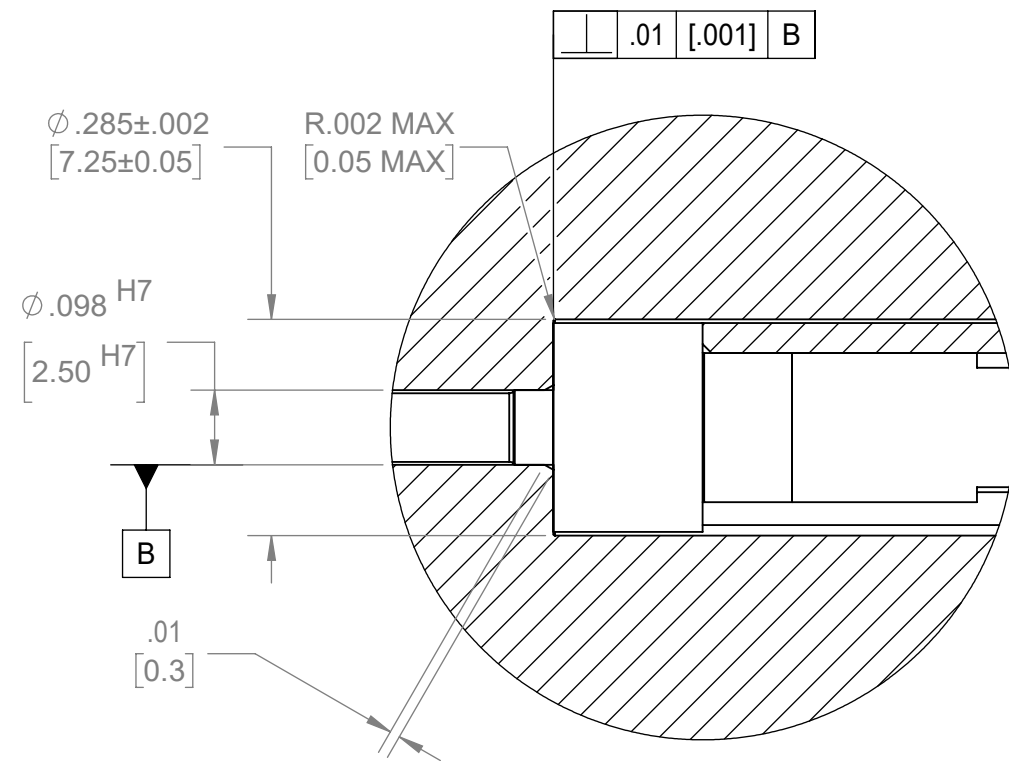
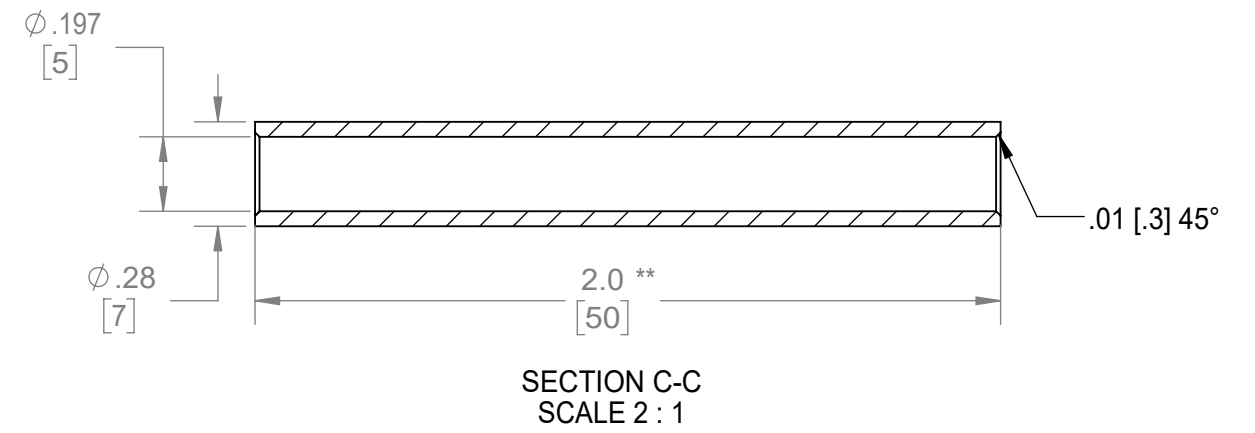
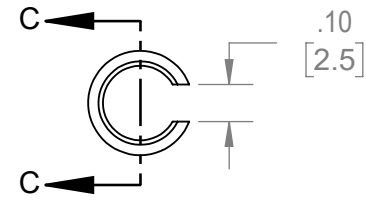
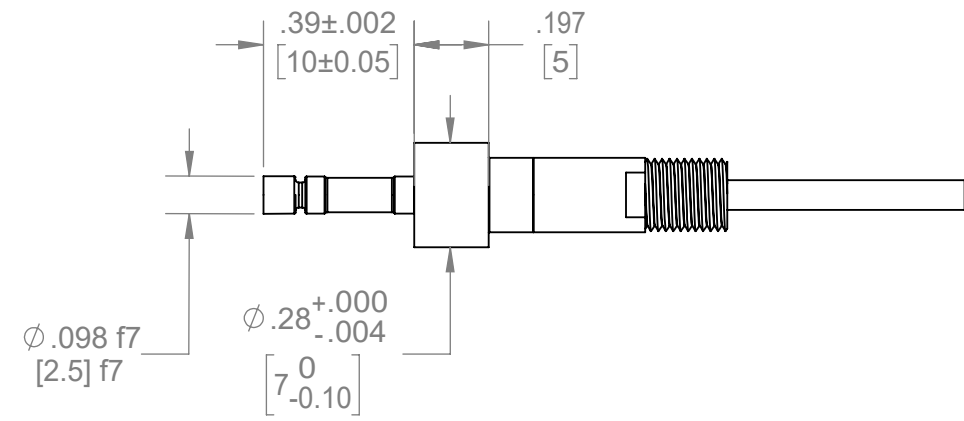

## INSTALLATION SPECIFICATIONS—RETAINING SLEEVE *(continued)*

### PLATE THICKNESS FOR CABLE CLEARANCE

Plate thickness 1.73" (44,0 mm [**1** at right])  
MIN for cable clearance.

### SENSOR TIP POCKET

Machine a pocket for the sensor tip with hole basis ISO standard fit H7h6—H7h6 is a locational clearance suitable for precision location fits. The sensor should fit without binding. The sensor tip should have a surface finish of 32 or better.

- Sensor tip diameter  $\varnothing$  0.098" H7 (2,50 mm [**2** at right]).
- Sensor tip length of 0.39" (10,0 mm [**3** at right]).

### SENSOR BODY AND RETAINING SLEEVE POCKET

Machine a pocket for the sensor body and retaining sleeve with hole basis H7h6. The sleeve should fit without binding.

- Sensor body and retaining sleeve pocket  $\varnothing$  0.285"  $\pm$ 0.002 (7,25 mm  $\pm$ 0,05 [**4** at right]).
- Chamfer 30° MIN/MAX 0.01/0.02" (0,3/0,4 mm [**5** at right]) where sensor tip and sensor body meet for ease of installation.

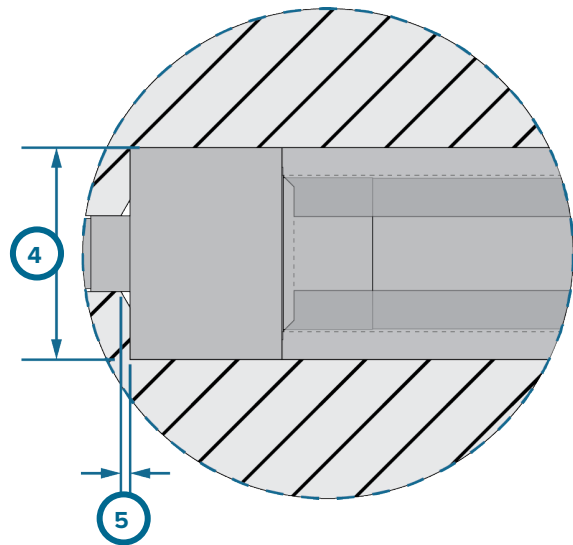
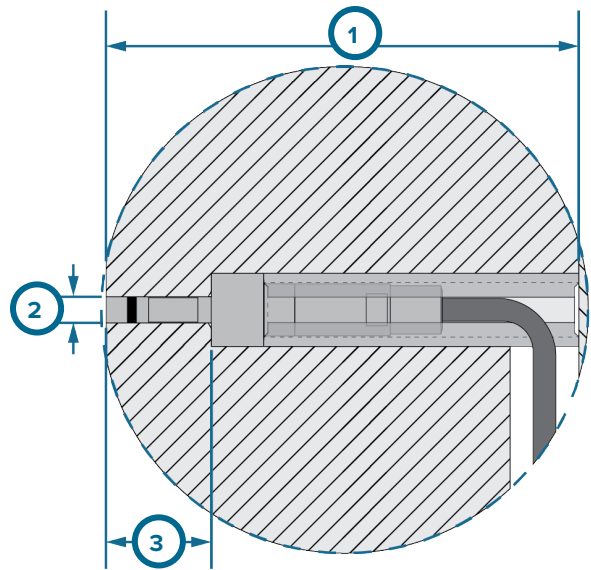

<b>1</b>	1.73" (44,0 mm) MIN
<b>2</b>	$\varnothing$ 0.098" (2,50 mm)
<b>3</b>	0.39" (10,0 mm)
<b>4</b>	$\varnothing$ 0.285" $\pm$ 0.002 (7,25 mm $\pm$ 0,05) MIN
<b>5</b>	Chamfer 30° 0.01/0.02" (0,3/0,4 mm) MIN/MAX

## SENSOR CABLE

### CABLE CHANNEL

Mill cable channel of 0.25 x 0.25" (6,4 x 6,4 mm [**1** at right]) to mold surface. Break all corners to avoid cable damage.

### EXCESS CABLE POCKET

If necessary, a cable pocket 1.00" (25,4 mm [**2** at right]) may be machined to store excess cable.

### SENSOR CABLE BEND

The sensor cable internal turn radius for the cable to coil is 0.197" (5 mm) MIN.

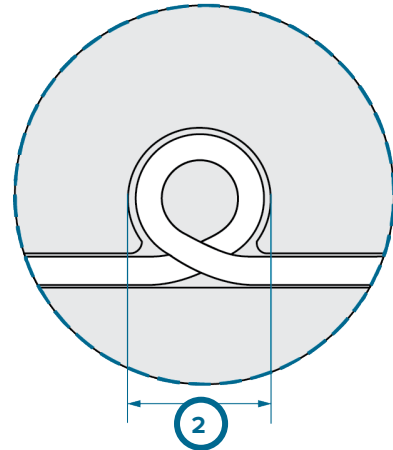
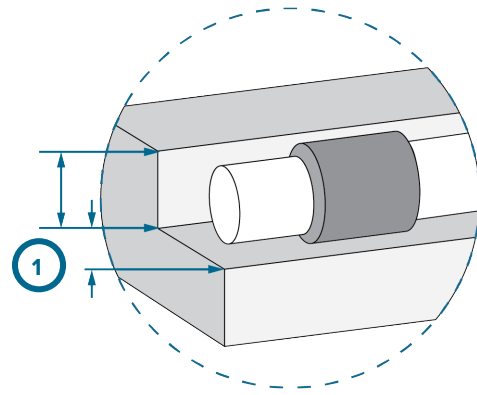

**1** 0.25 x 0.25" (6,4 x 6,4 mm)

**2** 1.00" (25,4 mm)

### SENSOR POCKET CHECK

The 4 mm Install Kit from RJG (purchased separately [**3** at right]) includes tools to form and verify sensor pocket dimensions for both the 4 mm piezoelectric flush mount cavity pressure sensor 6157 and the 6159.

RJG recommends the use of the 4 mm Install Kit for all 6157 and 6159 sensor installations. Read and follow all instructions provided with the kit to easily and correctly install and test the flush mount sensors.





## SENSOR TIP MACHINING

### OVERVIEW

Only grind the sensor if necessary to accurately fit the surface of the cavity; once a flush-mount sensor tip has been modified it cannot be re-calibrated. Read and follow all instructions, and refer to the provided figures to properly machine flush-mount sensors.

### DRY GRIND SPECIFICATIONS

Dry-grind the sensor head no more than 0.0005" (0,013 mm) per pass. Do not submerge the sensor head in fluids. Sensors are not watertight; keep all connectors clean and dry.

### CONTOURING SPECIFICATIONS

The sensor tip may be ground (dry) into a contour in order to match the cavity surface. Do not dry-grind the sensor head more than 0.0005" (0,013 mm) per pass. The sensor head may be contoured up to 0.02" (0,5 mm (1 at right]) from the top.

### ANGLE SPECIFICATIONS

The sensor tip may be ground (dry) into an angle in order to match the cavity surface. Do not dry grind the sensor head more than 0.0005" (0,013 mm) per pass. The sensor head may be ground to an angle of no more than 5°, and no more than 0.02" (0,5 mm (2 at right)).

### MACHINING SPECIFICATIONS

Dry-Grind (per pass)	0,013 mm	0.0005"
Contour	0,5 mm	0.02"
Angle 5°	0,5 mm	0.02"

Once a sensor is contoured or angled it can be installed into the tool in the proper orientation. Sensor alterations are not typically symmetrical, and ensuring that the sensor is correctly installed in the tool and that it remains in the proper orientation is critical.

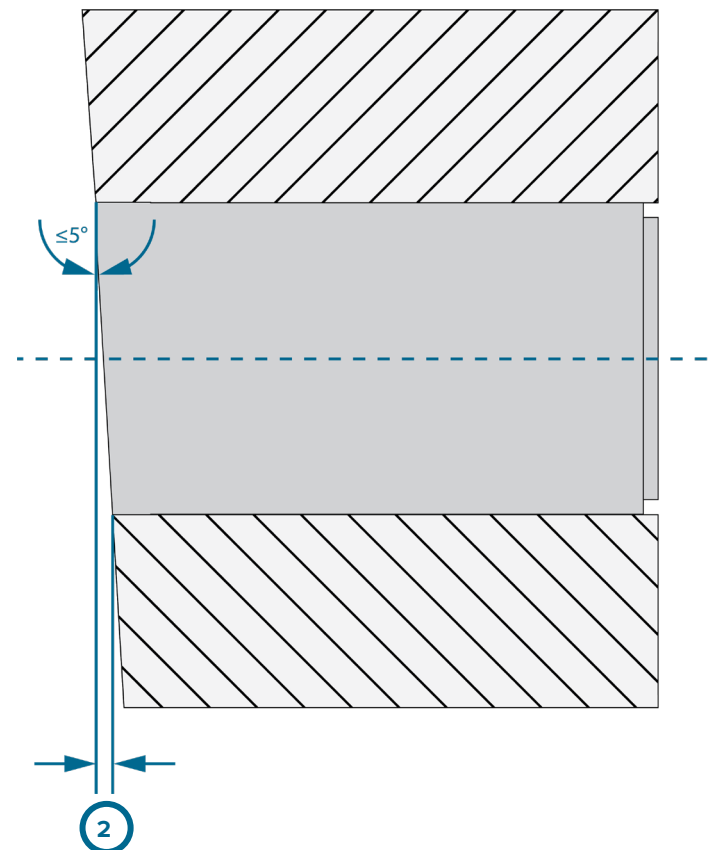
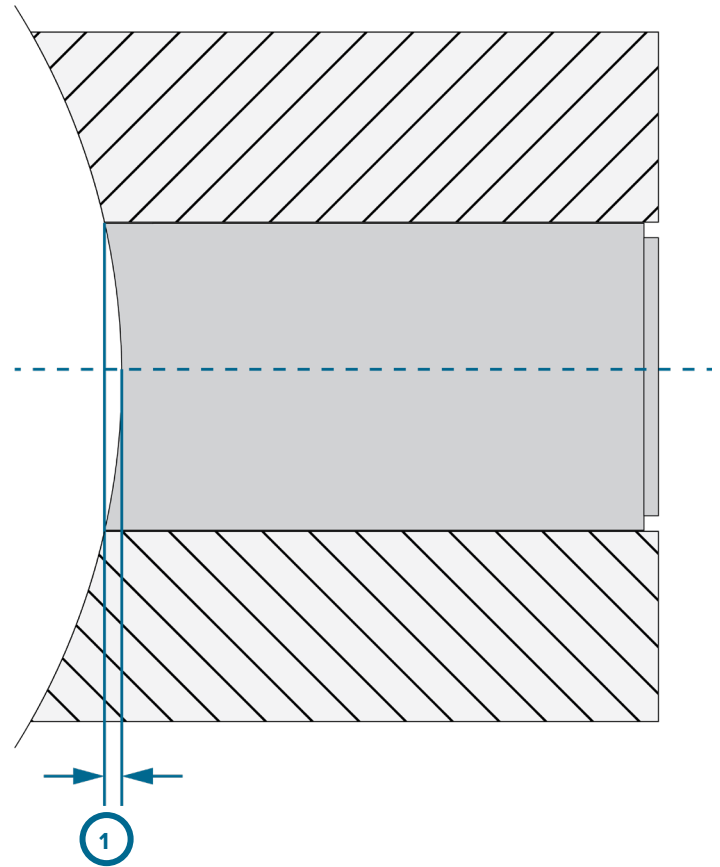

## ADDITIONAL MACHINING

### FLUSH MOUNT SENSOR KEYING

Keying of a sensor can prevent the unwanted rotation of installed sensors. The 6159 sensor can be keyed to a depth of up to 0.01" (0,3 mm) MAX, and at the length beginning from the front of the sensor back of 0.15" (3,7 mm) MAX. Read and follow all instructions to key a sensor—either for a previously-machined sensor pocket, or a new installation.

### SENSOR KEYING A NEW INSTALLATION

A new sensor installation can be keyed by grinding down a flat onto one side of the sensor and using a mill to machine the sensor pocket to match. When the sensor is installed in the sensor pocket, the contact of the flat, or keyed, surfaces will prevent sensor rotation (refer to figure at top right).

#### MACHINING SPECIFICATIONS

Dry Grind (per pass)	0,013 mm	0.0005"
Sensor Slot	0,3 mm	0.01"
Sensor Pocket Slot	0,3 mm	0.01"

### SENSOR KEYING A PREVIOUS POCKET

When a sensor pocket has previously been machined into a tool, a slot can be made on the sensor body and sensor pocket using a ball-nose end mill to create a keyway. A dowel is installed into the keyway created during milling to prevent sensor rotation (refer to figure at bottom right).

#### MACHINING SPECIFICATIONS

Milling (per pass)	0,013 mm	0.0005"
Sensor Slot	0,5 mm	0.02"
Sensor Pocket Slot	0,5 mm	0.02"

### SENSOR KEYING—NEW INSTALLATION

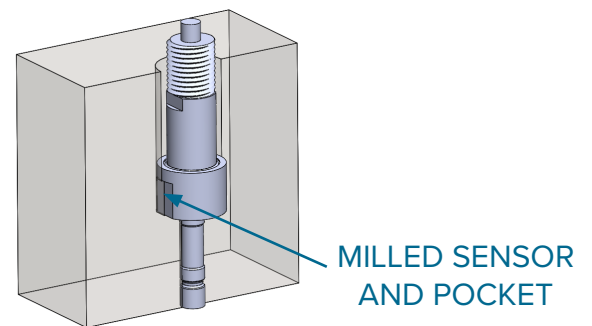
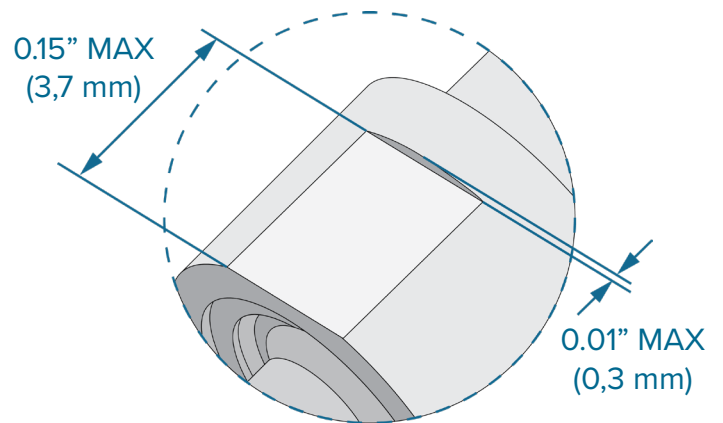

### SENSOR KEYING—PREVIOUS POCKET

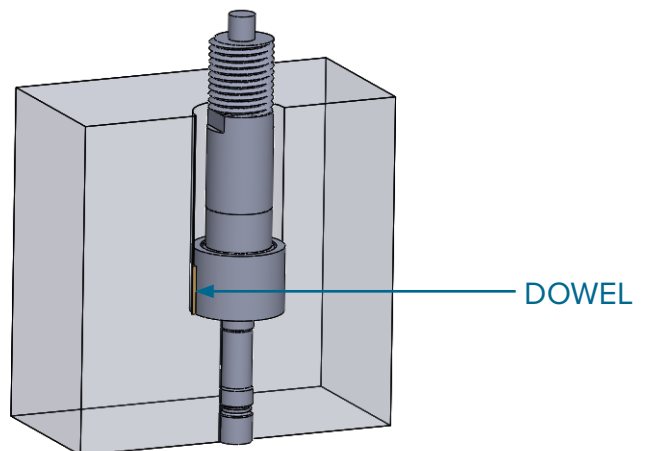
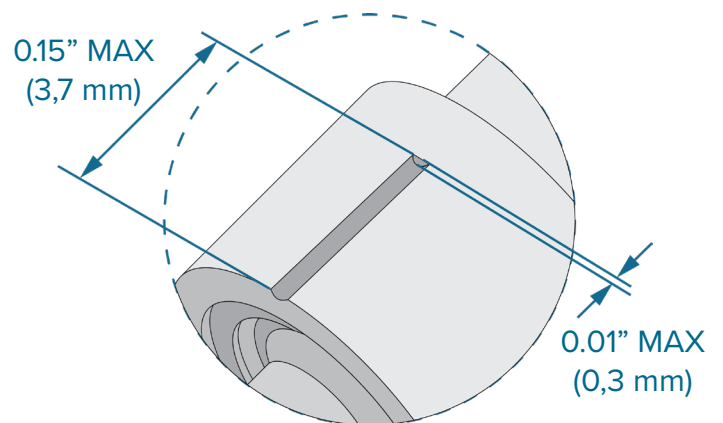

### CLEANING & DRIFT

#### REGULAR CLEANING

Pull sensors from the mold and clean out the pockets and channels when a mold is pulled for preventative maintenance. Sensors, connectors, and cables must be installed in areas free from oil, dirt, grime, and grease.

RJG, Inc. recommends the following cleaners:

- MicroCare MCC-CCC Contact Cleaner C
- MicroCare MCC-SPR SuprClean™
- Miller-Stephenson MS-730L Contact Re-Nu®

#### DRIFT

Piezoelectric sensors can drift negative (-) or positive (+). The acceptable drift specification for RJG piezoelectric sensors is 20 pC/minute. The easiest place to monitor this is the eDART “Sensor Locations” screen. Drift of  $\pm 20$  pC in sixty seconds indicates abnormal drift. The cause of “drift” is dirty/contaminated connections. This could be any of the connections from the sensor to the eDART.

Properly clean all connection points with an electronics grade contact cleaner. Allow the sensors and cables to air-dry before reconnecting them. Do not blow them out with a “shop” air line as this air usually contains oil and other contaminants.

If drift continues, clean the sensors out again with electronics grade cleaner then bake them in an oven to remove the contaminants (same method used at RJG). It is recommended to bake the sensors/ cables at 100 °C for sixty minutes.

If continuing to experience drift after this, please contact RJG Sales for pricing and lead time on replacement items.

#### TESTING & CALIBRATION

Follow all instructions and recommendations for individual sensor testing and calibration for optimal operation.

#### SENSOR TESTING

##### 1. Sensor PreCheck

The Sensor PreCheck provides diagnostics on typical sensor problems such as sensor drift, preload, and zero shift, and can also detect sensor installation errors caused by improper pocket dimensions, damaged wires, and damaged sensor heads. A test report with sensor configuration can be emailed or printed from the device. This device allows testing of up to thirty-two sensors at one time and can verify that a force was applied to the sensor.

##### 2. eDART Software—Raw Data Viewer

The eDART Raw Data Viewer displays the status of the sensor, either Valid, No Reply, Stale, or Invalid.

- A Valid sensor has raw counts that change when force is applied to the sensor; this indicates a properly working sensor.
- A No Reply sensor is not communicating with the eDART; the sensor may be unplugged.
- A Stale sensor indicates a sensor that is unused.
- An Invalid sensor will indicate a Failure of either Over-range (Ovrng) or Under-range (Undrng). The Ovrng indicates the sensor’s calibration has changed too far in a positive direction, outside of the upper specification. The Undrng indicates that the sensor’s calibration has changed too far in a negative direction, and the sensor may report a number below zero when load is applied.

## WARRANTY

### RJG, INC. STANDARD THREE-YEAR WARRANTY

RJG, Inc. is confident in the quality and robustness of the 6519 sensors, and so are offering a three-year warranty on all RJG cavity pressure sensors. RJG's cavity pressure sensors are guaranteed against defects in material and workmanship for three years from the ship date. The warranty is void if it is determined that the sensor was subjected to abuse or neglect beyond the normal wear and tear of field use, or in the event the sensor has been opened by the customer. This new warranty policy is the most generous offered in the cavity pressure sensor industry, with one year being the most common.

### PRODUCT DISCLAIMER

RJG, Inc. is not responsible for the improper installation of this equipment, or any other equipment RJG manufactures.

Proper RJG equipment installation does not interfere with original equipment safety features of the machine. Safety mechanisms on all machines should never be removed.

## TROUBLESHOOTING

### COMMON ERRORS

#### SENSOR HEAD ISSUES

Sensor head is placed under a steel shut-off (1 at right). The sensor must not be placed in a steel shut-off area; failure to comply will result in failure of sensor to produce the desired data outcomes.

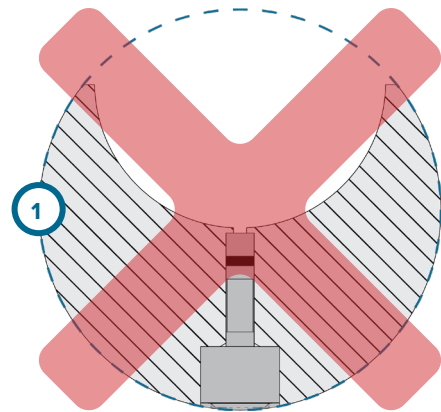

The sensor retaining nut is over-tightened, crushing the sensor (2 at right). Do not over tighten the retaining nut when installing the sensor; failure to comply will result in destruction of sensor.

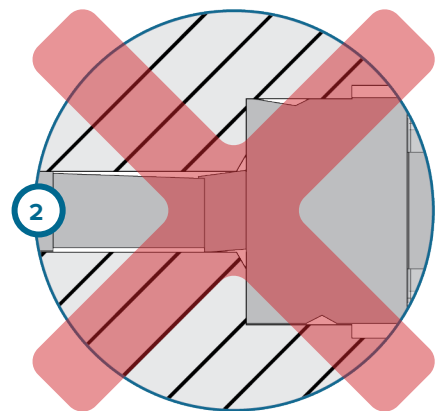

#### CABLE ISSUES

Sensor cable is pinched during mold assembly (3 at right). The sensor cable(s) must never be pinched in the mold assembly; failure to comply will result in failure of sensor to produce the desired data outcomes, and damage or destruction of cable.

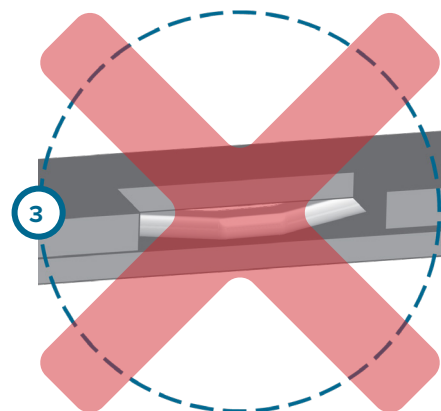

## SENSOR DRIFT

Piezoelectric sensors may experience drift if connections are dirty/contaminated, or have a sensor cable that is damaged. There are three types of drift that the sensors may produce.

### 3. Slow sensor drift reading.

A sensor reading that slowly rises or falls (positive or negative) from the set zero value.



### 4. Fast sensor drift/invalid reading.

A sensor reading that quickly rises or falls (positive or negative) from the set zero value, possibly so much that the reading becomes invalid.

### 5. No sensor/eDART/CoPilot communication.

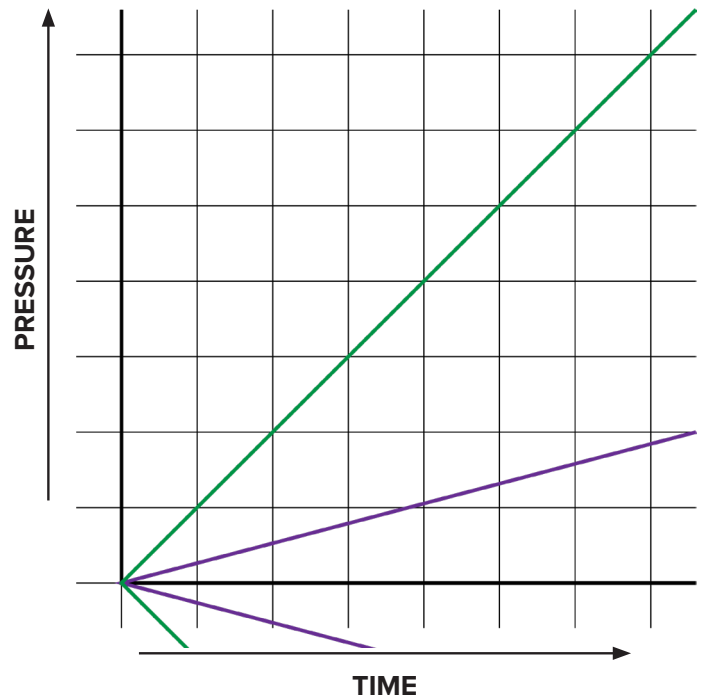
The sensor reading cannot be obtained by the eDART/CoPilot.



Piezoelectric Sensor Drift Type Graph	
	Fast Drift/Invalid
	Slow Drift

## COMMON ERRORS *(continued)*

### SLOW SENSOR DRIFT READING

If the sensor reading will not remain steady and drifts positive or negative, the sensor, cables, or adapter connectors may be contaminated. To identify the connector(s) with contamination, perform the following:

1. Disconnect sensor from 1645 or C-PZ/1645 cable and clean ends; if reading continues to drift, continue to next step.
2. Disconnect the 1645 or C-PZ/1645 from the sensor connector or adapter and clean ends; if the reading continues to drift, continue to next step.
3. If applicable, disconnect cable from the sensor connector and clean end and connector; if the reading continues to drift, continue to next step.
4. If applicable, disconnect cable from adapter and clean end and connector; if the reading continues to drift, continue to next step.

If the sensor reading continues to drift after the above troubleshooting steps are completed, either the sensor, cables, connector, or adapter must be replaced.

#### SINGLE-CHANNEL



#### MULTI-CHANNEL

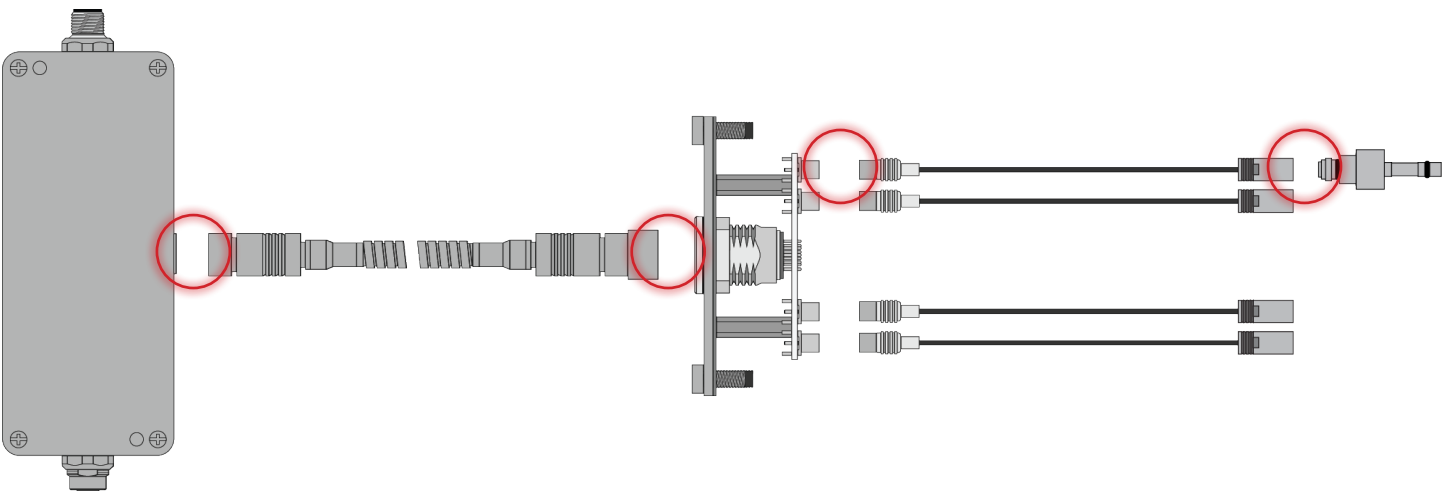

## COMMON ERRORS *(continued)*

### FAST SENSOR DRIFT/INVALID READING

If the sensor reading drifts quickly and becomes invalid, the sensor, cables, or adapter connectors may be heavily contaminated, or the adapter may have failed. To identify the connector(s) with contamination, perform the following:

1. Disconnect sensor from 1645 or C-PZ/1645 cable and clean ends; if reading continues to drift, continue to next step.
2. Disconnect the 1645 or C-PZ/1645 from connector or adapter and clean ends; if the reading continues to drift, continue to next step.
3. If applicable, disconnect cable from the sensor connector and clean end and connector; if the reading continues to drift, continue to next step.
4. If applicable, disconnect cable from the adapter and clean end and connector; if the reading continues to drift, continue to next step.

If the sensor reading continues to drift or remains invalid after the above troubleshooting steps are completed the adapter must be replaced.

#### SINGLE-CHANNEL



#### MULTI-CHANNEL

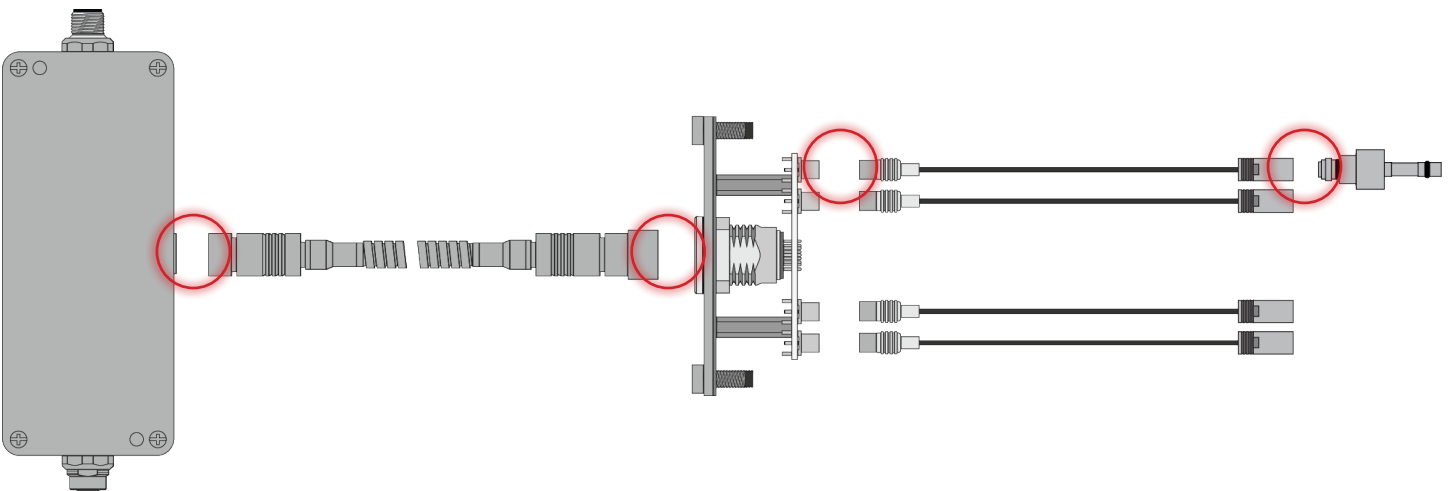



## COMMON ERRORS *(continued)*

### SENSOR DOES NOT COMMUNICATE WITH eDART/COPILOT

If the eDART/CoPilot system is unable to establish communication with the sensor, the cables or adapter may have failed. To identify the failed component, perform the following;

1. Replace the 1645 or C-PZ/1645 sensor cable with working cable; test sensor operation. If communication remains non-existent, continue to next step.
2. Replace the sensor connector cable with working cable; test sensor operation. If communication remains non-existent, continue to next step.
3. If applicable, replace the sensor adapter cable with working cable; test sensor operation. If communication remains non-existent, continue to next step.
4. Replace the CE-LX5 Lynx cable with working cable; test the sensor operation.

If the eDART/CoPilot system cannot establish communication after these steps, the connector has failed and must be replaced.

#### SINGLE-CHANNEL



#### MULTI-CHANNEL

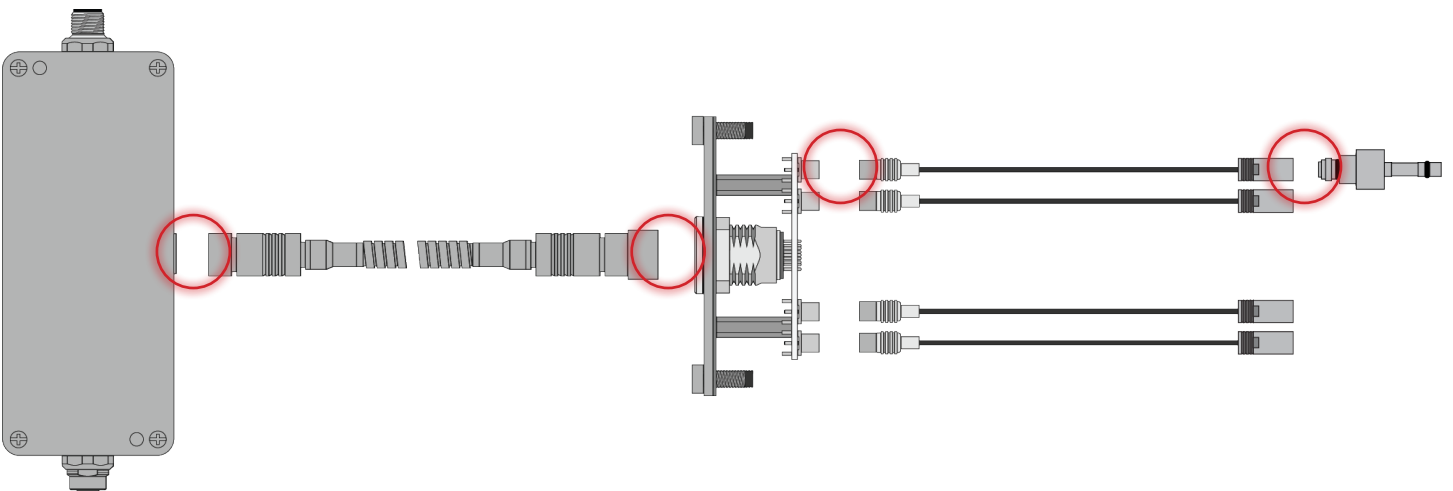

## CUSTOMER SUPPORT

Contact RJG's Customer Support team by phone or email.

RJG, Inc. Customer Support

P: 800.472.0566 (Toll Free)

P: +1.231.933.8170

[www.rjginc.com/support](http://www.rjginc.com/support)

**Contact Support**

**General Questions** | RMA Request | Sensor Selection & Placement

Have a question? We're here for you! Be sure to check out our knowledge base first to see if you can find the answer to your question there. Or please feel free to reach out to our customer support team anytime at:

Email: [support@rjginc.com](mailto:support@rjginc.com)  
Phone: +1(231) 933-8170 Or Toll Free: +1(800) 472-0566  
Or complete the form below:

<b>First Name *</b>	<b>Last Name *</b>	<b>Company</b>
First Name*	Last Name*	Company*
<b>Job Title *</b>	<b>Phone *</b>	<b>Email *</b>
Job Title*	Phone Number*	Email Address*

## RELATED PRODUCTS

The 6159 is compatible with other RJG, Inc. products for use with the eDART or CoPilot process control and monitoring system.

### COMPATIBLE PRODUCTS

#### LYNX CABLES CE-LX5

The Lynx sensor cable (1 at right) is a polypropylene-coated cable suited for the heat and stress found in injection molding environments. The cable is available in lengths from 12–472” (0,3–12 m), and can be ordered with straight or 90° fittings. One CE-LX5 is required to interface the single-channel sensor adapters LP/LX1-M or PZ/LX1-S with the eDART or CoPilot system.



#### SINGLE-CHANNEL PIEZOELECTRIC SENSOR CABLE 1645

The single-channel piezoelectric sensor cable 1645 (2 at right) is a PTFE/FEP coaxial cable suited for the injection molding environment. The cable is available in several lengths from 0.2–2.0 m (7.9–78.7”). One 1645 is required to interface the 9204 with a Lynx single-channel piezoelectric sensor adapter and the eDART or CoPilot system.



#### MULTI-CHANNEL PIEZOELECTRIC SENSOR CABLE C-PZ/1645

The multi-channel piezoelectric sensor cable C-PZ/1645 (3 at right) is a PTFE/FEP coaxial cable suited for the injection molding environment. The cable is available in several lengths from 0.2–2.0 m (7.9–78.7”). One C-PZ/1645 is required to interface each 9204 with a Lynx multi-channel piezoelectric sensor connector and the eDART or CoPilot system.



## SIMILAR PRODUCTS

RJG, Inc. offers a wide array of cavity pressure sensors for each application—piezoelectric, strain gage, single-channel, multi-channel, and digital.

### FLUSH-MOUNT 4 MM PIEZOELECTRIC CAVITY PRESSURE SENSOR 6157

The 6157 (1 at right) flush-mount piezoelectric sensor from RJG, Inc. is a single- or multi-channel, 4 mm sensor that can withstand forces of up to 29,000 psi (2,000 bar) and maximum temperatures of 392 °F (200 °C).



### SINGLE/MULTI-CHANNEL 3.5 MM PIEZOELECTRIC SENSOR 9210

The 9210 (2 at right) single- or multi-channel 3.5 mm piezoelectric sensor is a button-style cavity pressure sensor that can withstand forces up to 56 lb (250 N) and temperatures up to 392 °F (200 °C).



### SINGLE/MULTI-CHANNEL 6 MM PIEZOELECTRIC SENSOR 9211

The 9211 (3 at right) single- or multi-channel 6 mm piezoelectric sensor is a button-style cavity pressure sensor that can withstand forces up to 562 lb (2.5 kN) and temperatures up to 392 °F (200 °C).





## LOCATIONS / OFFICES

### USA

#### **RJG USA (HEADQUARTERS)**

3111 Park Drive  
Traverse City, MI 49686  
P +01 231 947-3111  
F +01 231 947-6403  
sales@rjginc.com  
www.rjginc.com

### ITALY

#### **NEXT INNOVATION SRL**

Milano, Italy  
P +39 335 178 4035  
sales@it.rjginc.com  
it.rjginc.com

### MEXICO

#### **RJG MEXICO**

Chihuahua, Mexico  
P +52 614 4242281  
sales@es.rjginc.com  
es.rjginc.com

### SINGAPORE

#### **RJG (S.E.A.) PTE LTD**

Singapore, Republic of  
Singapore  
P +65 6846 1518  
sales@swg.rjginc.com  
en.rjginc.com

### FRANCE

#### **RJG FRANCE**

Arnithod, France  
P +33 384 442 992  
sales@fr.rjginc.com  
fr.rjginc.com

### CHINA

#### **RJG CHINA**

Chengdu, China  
P +86 28 6201 6816  
sales@cn.rjginc.com  
zh.rjginc.com

### GERMANY

#### **RJG GERMANY**

Karlstein, Germany  
P +49 (0) 6188 44696 11  
sales@de.rjginc.com  
de.rjginc.com

### KOREA

#### **CAEPRO**

Seoul, Korea  
P +82 02-2113-1870  
sales@ko.rjginc.com  
www.caepro.co.kr

### IRELAND/UK

#### **RJG TECHNOLOGIES, LTD.**

Peterborough, England  
P +44(0)1733-232211  
info@rjginc.co.uk  
www.rjginc.co.uk