

# Lynx™ 7-Channel Sequence Input Module - ID7-D-SEQ

The ID7-D-SEQ is a DIN mountable Sequence Input Module that acts as an interface between machine operations and the eDART System™. With the Sequence Module, it is unnecessary to wire all of the machine signals. The eDART™ software takes what is easily available from the machine and derives the rest. This is important when implementing a network or installing on a portable basis because many times the signals are not readily available.



Always power down before working on any equipment

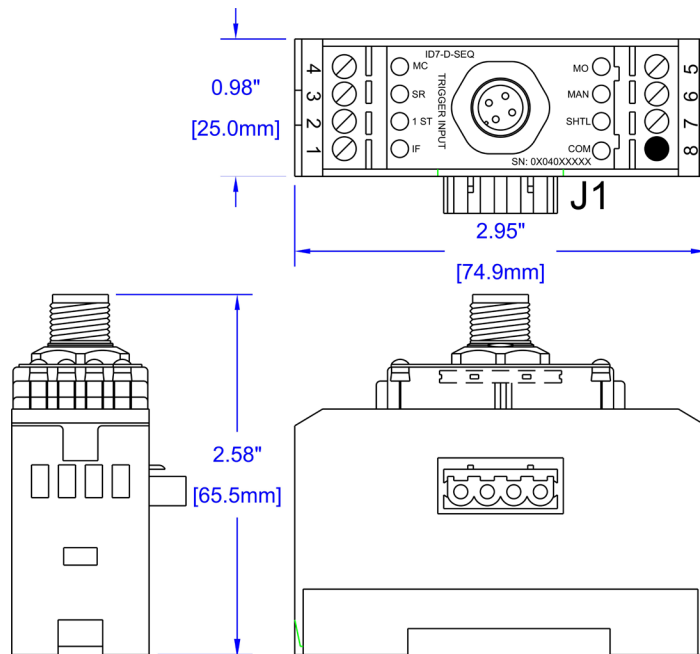

Figure 3: Lynx™ 7- Channel Sequence Input Module

The Sequence Module is designed for mounting on standard 35mm DIN rail often found in machine panels. Once mounted, connectors interface the unit with other Lynx™ DIN rail modules and with the eDART System™.

For information on connecting the RJG system to your specific machine, please visit <http://rjginc.com/resources/wiring>

If you don't see your machine listed at the website above, please email the following information; machine manufacturer, machine model and serial number to [machinetriggerinfo@rjginc.com](mailto:machinetriggerinfo@rjginc.com) and we will contact the machine manufacturer to get the information for you.

If you have any questions you can also contact Customer Support at **231-947-3111 x170**

The digital signals are connected to the Sequence Module through the eight terminal connectors (see Figure 3). The signals themselves are connected to terminals 1-7 and the signal common for these is wired to terminal 8. These signals can be taken directly from the machine controller and can operate at 24VDC.

Connection	Function
Terminal 1	INJ Forward
Terminal 2	1st Stage
Terminal 3	Screw Run
Terminal 4	Mold Clamped
Terminal 5	Mold Opening
Terminal 6	Manual
Terminal 7	Shuttle Position
Terminal 8	Input Common

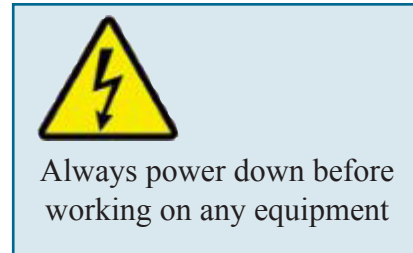

Table 3: Sequence Input Module Terminal Connections

Technical Specifications	
Power (supplied by eDART)	12VDC
Current Draw	45mA
Absolute Maximum Input Voltage	36VDC
Minimum Trigger on Voltage	18VDC

Table 4: Sequence Input Module Technical Specifications

The sequence module can be interfaced with a machine output card as shown in the figure below. See Table 4 for voltage ranges. The Sequence Module inputs these voltage signals using an opto-isolated circuit to ensure full isolation from the machine controller.

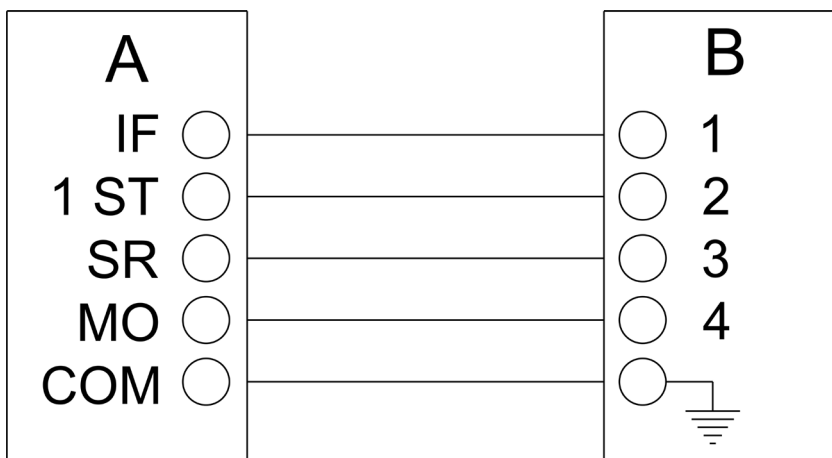

Figure 4: Input Module Interfacing with a machine output card

## Wiring Machine Signals

In order to perform important computations necessary for successful injection molding processes, the eDART™ must have accurate sequence signals from the machine controller. These signals indicate to the eDART™ when important events occur during the machine cycle and they help synchronize signals from the hydraulic and mold pressure sensors to the actions of the machine for display in the software.

Table 5 details these signals in order of importance to the software. If none of these signals is available, please contact your RJG, Inc. representative for alternatives or more information.

Machine Signal	Wire to	Should go ON when	Should go OFF when	Purpose
Screw Run	SR	Screw motor starts	Screw motor stops	Stroke direction, zero and material variation information (required for control)
Injection Forward	IF	Injection starts	Hold time ends	Searches for peaks, hold pressure, etc. (required for control)
Mold Clamped	MC	Mold clamped to pressure	Mold cracks	Accurate cycle time and integration limit (resets piezoelectric adapters)
Mold Opening	MO	Mold begins to open	Mold stops opening	Pinched part detection (resets piezoelectric adapters)
First Stage	1 ST	Start of injection (Velocity)	Switch to pressure (hold)	Creates internal injection forward, pack and in 2-Stage, "FILL"
Manual Mode	MAN	Machine is in manual mode (for setup)	Machine is in auto or semi-automatic mode	Prevents parts counts in manual mode.
Shuttle Position	SHTL	Should be on at start of cycle - position 2	Should be on at start of cycle - position 1	Detects mold position in 2-position shuttle molding
Mold Closing	Any	Mold begins to close	Mold touches or clamps up	Cycle time with mold opening (resets piezoelectric adapters)
Mold Open	Any	Mold reaches open	Mold starts to close	Cycle time and integration limit (resets piezoelectric adapters)
Second Stage	Any	Switch to pressure (hold)	End of hold (end injection)	Creates internal injection forward and pack

Table 5: Machine sequence timing details